

Installation and service instructions for contractors

VIESMANN

Vitodens 111-W

Type B1LF, 3.2 to 32 kW

Type B1LF-M (for multiple connection), 5.7 to 32 kW

Wall mounted gas condensing boiler

Natural gas and LPG version

Gas Council Number: 47-819-53, 47-819-54



VITODENS 111-W



Safety instructions

-  Please follow these safety instructions closely to prevent accidents and material losses.

Safety instructions explained

-  **Danger**
This symbol warns against the risk of injury.

-  **Please note**
This symbol warns against the risk of material losses and environmental pollution.

Note
Details identified by the word "Note" contain additional information.

Target group

These instructions are exclusively intended for qualified contractors.

- Work on gas installations may only be carried out by a registered gas fitter.
- Work on electrical equipment may only be carried out by a qualified electrician.
- The system must be commissioned by the system installer or a qualified person authorised by the installer.

Regulations to be observed

- National installation regulations
- Statutory regulations for the prevention of accidents
- Statutory regulations for environmental protection
- Codes of practice of the relevant trade associations
- Relevant country-specific safety regulations

Safety instructions for working on the system

Working on the system

- Where gas is used as the fuel, close the main gas shut-off valve and safeguard it against unintentional reopening.
- Isolate the system from the power supply, e.g. by removing the separate fuse or by means of a mains isolator, and check that it is no longer live.
- Safeguard the system against reconnection.
- Wear suitable personal protective equipment when carrying out any work.

Safety instructions (cont.)**Danger**

Hot surfaces and fluids can lead to burns or scalding.

- Before maintenance and service work, switch OFF the appliance and let it cool down.
- Never touch hot surfaces on the boiler, burner, flue system or pipe-work.

**Please note**

Electronic assemblies can be damaged by electrostatic discharge. Prior to commencing work, touch earthed objects such as heating or water pipes to discharge static loads.

Repair work**Please note**

Repairing components that fulfil a safety function can compromise the safe operation of the system. Replace faulty components only with genuine Viessmann spare parts.

Auxiliary components, spare and wearing parts**Please note**

Spare and wearing parts that have not been tested together with the system can compromise its function. Installing non-authorised components and making non-approved modifications or conversions can compromise safety and may invalidate our warranty. For replacements, use only original spare parts supplied or approved by Viessmann.

Safety instructions for operating the system

If you smell gas

-  **Danger**
Escaping gas can lead to explosions which may result in serious injury.
- Do not smoke. Prevent naked flames and sparks. Never switch lights or electrical appliances on or off.
 - Close the gas shut-off valve.
 - Open windows and doors.
 - Evacuate any people from the danger zone.
 - Notify your gas or electricity supply utility from outside the building.
 - Have the power supply to the building shut off from a safe place (outside the building).

If you smell flue gas

-  **Danger**
Flue gas can lead to life threatening poisoning.
- Shut down the heating system.
 - Ventilate the installation site.
 - Close doors to living spaces to prevent flue gases from spreading.

What to do if water escapes from the appliance

-  **Danger**
If water escapes from the appliance there is a risk of electrocution. Switch OFF the heating system at the external isolator (e.g. fuse box, domestic distribution board).

-  **Danger**
If water escapes from the appliance there is a risk of scalding. Never touch hot heating water.

Condensate

-  **Danger**
Contact with condensate can be harmful to health. Never let condensate touch your skin or eyes and do not swallow it.

Flue systems and combustion air

Ensure that flue systems are clear and cannot be sealed, for instance due to accumulation of condensate or other external causes. Ensure an adequate supply of combustion air. Inform system users that subsequent modifications to the building characteristics are not permissible (e.g. cable/pipe-work routing, cladding or partitions).

-  **Danger**
Leaking or blocked flue systems, or an inadequate supply of combustion air can cause life threatening poisoning from carbon monoxide in the flue gas. Ensure the flue system is in good working order. Vents for supplying combustion air must be non-sealable.

Extractors

Operating appliances that exhaust air to the outside (extractor hoods, extractors, air conditioning units, etc.) can create negative pressure. If the boiler is operated at the same time, this can lead to a reverse flow of flue gas.

Safety instructions (cont.)**Danger**

The simultaneous operation of the boiler and appliances that exhausts air to the outside can result in life threatening poisoning due to a reverse flow of flue gas.

Fit an interlock circuit or take suitable steps to ensure an adequate supply of combustion air.

1. Information	Disposal of packaging	8
	Gas Council No.	8
	Symbols	8
	Intended use	9
	Product information	9
	■ Vitodens 111-W, type B1LF	9
	System examples	9
	Spare parts lists	9
2. Preparing for installation	10
3. Installation sequence	Removing the boiler from the packaging	12
	Mounting the boiler and making connections	12
	■ Mounting the boiler on the pre-plumbing jig or mounting frame	12
	■ Fitting the boiler to the wall mounting bracket	15
	■ Removing the front panel	17
	■ Type plate	17
	■ Connections on the heating water and DHW sides	18
	Condensate connection	18
	■ Filling the trap with water	19
	Flue gas connection	19
	Gas connection	21
	■ Gas installation to BS 6891:2005	22
	Electrical connections	22
	■ Opening the wiring chamber	22
	■ Layout of the electrical connections	23
	■ On-site connections on the HMBU heat management unit	25
	■ Outside temperature sensor	25
	■ Floating switching contact connection	25
	■ Power supply ⁴⁰	27
	■ Routing connecting cables/leads	27
	WiFi operational reliability and system requirements	28
	■ Wireless signal range of WiFi connection	28
	■ Angle of penetration	29
	Closing the wiring chamber and fitting the front panel	30
4. Commissioning, inspection, maintenance	Steps - commissioning, inspection and maintenance	31
5. System configuration (parameters)	Calling up parameters	58
	Parameter	58
	■ Additional settings can be made only via software tool	61
	Subscriber numbers of connected extensions	62
6. Diagnosis and service checks	Service menu	64
	■ Calling up the service menu	64
	■ Exiting the service menu	64
	Diagnosis	65
	■ Checking operating data	65
7. Troubleshooting	Fault display on the programming unit	66
	Overview of electronics modules	67
	Fault messages	67
	Repairs	83
	■ Draining the boiler on the heating water side	83
	■ Draining the boiler on the DHW side	84
	■ Removing the boiler from the pre-plumbing jig or mounting frame	85
	■ Status/checking/diagnosing the internal circulation pump	85
	■ Checking the temperature sensors	87
	■ Information on replacing the HMBU heat management unit	89

Index (cont.)

	<ul style="list-style-type: none"> ■ Replacing the power cable 89 ■ Replacing the HMI connecting cable 90 ■ Checking the plate heat exchanger 90 ■ Removing the hydraulic unit 91 ■ Checking the fuse 92 	
8. Function description	<ul style="list-style-type: none"> Appliance functions 93 ■ Heating mode 93 ■ Venting program 93 ■ Filling program 93 ■ Heating curve 93 ■ Screed drying 95 DHW heating 97 ■ Heating the DHW loading cylinder from cold 97 ■ Reheating when DHW is drawn off 97 External heating circuit hook-up (if installed) 97 	
9. Connection and wiring diagram	HBMU heat management unit 98	
10. Commissioning/service reports 101	
11. Specification	<ul style="list-style-type: none"> Specification 102 Specification 102 Electronic combustion control unit 106 	
12. Disposal	Final decommissioning and disposal 107	
13. Certificates	<ul style="list-style-type: none"> Declaration of conformity 108 Manufacturer's certificate according to the 1st BImSchV [Germany] 108 	
14. Keyword index 109	









Disposal of packaging

Please dispose of packaging waste in line with statutory regulations.







Gas Council No.

Type	Gas Council Number:
Vitodens 111-W, B1LF, 25 kW storage combi	47-819-53
Vitodens 111-W, B1LF, 32 kW storage combi	47-819-54

Symbols

Symbol	Meaning
	Reference to other document containing further information
	Step in a diagram: The numbers correspond to the order in which the steps are carried out.
	Warning of material losses and environmental pollution
	Live electrical area
	Pay particular attention.
	<ul style="list-style-type: none"> Component must audibly click into place. or Acoustic signal
	<ul style="list-style-type: none"> Fit new component. or In conjunction with a tool: Clean the surface.
	Dispose of component correctly.
	Dispose of component at a suitable collection point. Do not dispose of component in domestic waste.

The steps in connection with commissioning, inspection and maintenance are found in the "Commissioning, inspection and maintenance" section and identified as follows:

Symbol	Meaning
	Steps required during commissioning
	Not required during commissioning
	Steps required during inspection
	Not required during inspection
	Steps required during maintenance
	Not required during maintenance

Intended use

The appliance is intended solely for installation and operation in sealed unvented heating systems that comply with EN 12828 (as well as CECS215-2017 and CE: CS215-2017 in relation to CN), with due attention paid to the associated installation, service and operating instructions. It is only designed for heating up heating water that is of potable water quality.

Intended use presupposes that a fixed installation in conjunction with permissible, system-specific components has been carried out.

Commercial or industrial usage for a purpose other than heating the building or DHW shall be deemed inappropriate.

Any usage beyond this must be approved by the manufacturer in each individual case.

Incorrect usage or operation of the appliance (e.g. the appliance being opened by the system user) is prohibited and will result in an exclusion of liability. Incorrect usage also occurs if the components in the heating system are modified from their intended use (e.g. if the flue gas and ventilation air paths are sealed).

Product information

Vitodens 111-W, type B1LF

Gas condensing storage combi boiler with Inox-Radial heat exchanger and the following integrated components:

- Modulating MatriX-Plus burner for natural gas and LPG
- Stainless steel loading cylinder, 46 l capacity
- Hydraulics with 3-way diverter valve and variable speed high efficiency circulation pump
- Weather-compensated or constant temperature control unit
- Integral diaphragm expansion vessel (10 l capacity)

The selected gas category in the delivered condition and the associated nominal gas pressure are given on the boiler type plate. The type plate also shows the other gas types and pressures with which the boiler can be operated. A conversion within the stated natural gas groups is not required. For conversion to LPG (without conversion kit), see "Commissioning, inspection and maintenance".

The Vitodens 111-W may only be delivered to countries listed on the type plate. For deliveries to other countries, approved contractors must arrange individual approval on their own initiative and in accordance with the law of the country in question.

System examples

System examples with hydraulic and electrical connection diagrams and function descriptions are available to help setting up the heating system.

Detailed information on system examples can be found at: www.viessmann-schemes.com

Spare parts lists

Information about spare parts can be found at www.viessmann.com/etapp or in the Viessmann spare part app.



Preparing for installation

Installation

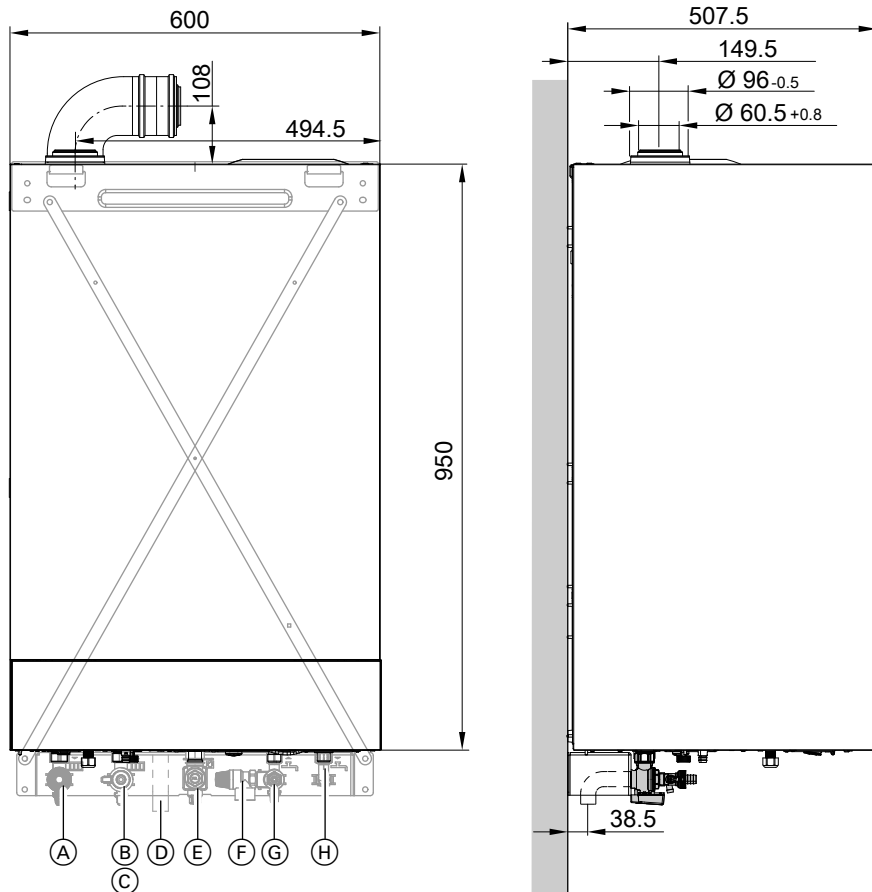

Fig. 1

- Ⓐ Heating flow
- Ⓑ Heating return
- Ⓒ Filling/draining
- Ⓓ Condensate drain
- Ⓔ Gas connection
- Ⓕ Safety valve
- Ⓖ Cold water
- Ⓗ DHW

Note

This boiler (IP rating: IP X1) is approved for installation in wet rooms inside safety zone 3. Exposure to water jets and spray must be prevented.

For open flue operation, the boiler may only be operated with a splash cover.

Observe the requirements of DIN VDE 0100.

Preparing for installation (cont.)

Installation

1. Subject to order: Fit supplied pre-plumbing jig, mounting frame or wall mounting bracket in the relevant installation location.



Installation instructions for pre-plumbing jig or mounting frame

Note

Check the condition of the wall where the boiler is to be installed. For the suitability of the supplied rawl plugs for various building materials, see manufacturer's instructions: Fischer expansion plugs SX 10 x 80

For other construction materials, use fixing materials with sufficient load bearing capacity.

2. Prepare the water connections to the valves/fittings of the mounting bracket. Thoroughly flush the heating system.



Please note

To prevent appliance damage, connect all pipework so that it is free of load and torque stress.

3. Prepare the gas connection according to TRGI or TRF [or local regulations].

4. Prepare the electrical connections.

- The appliance is delivered fitted with a power cable (approx. 2 m long).

Note

Connect the power cable to the electricity supply using a fixed connection.

- Power supply: 230 V, 50 Hz, fuse rating max. 16 A
- Accessory cables: 0.75 mm² flexible PVC cable with required number of cores for external connections

Connection on the DHW side

Cold water installation

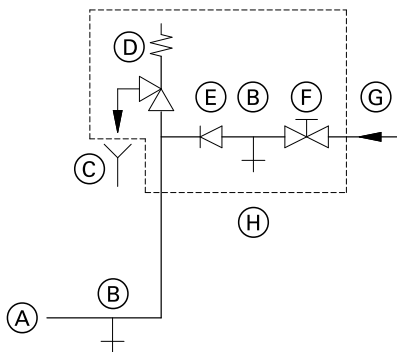

Fig. 2

- Ⓐ Cold water connection of boiler
- Ⓑ Drain outlet

- Ⓒ Visible discharge pipe outlet point
- Ⓓ Safety valve
- Ⓔ Non-return valve
- Ⓕ Shut-off valve
- Ⓖ Cold water
- Ⓗ Safety assembly

Safety assembly Ⓗ is included in the standard delivery and requires installing.

Only use a non-return valve or a combined shut-off and non-return valve in conjunction with a safety valve. If the safety valve is used, the cold water shut-off valve on the boiler must not be shut off. Remove the toggle on the cold water shut-off valve (if installed) to prevent manual shut-off.

Removing the boiler from the packaging

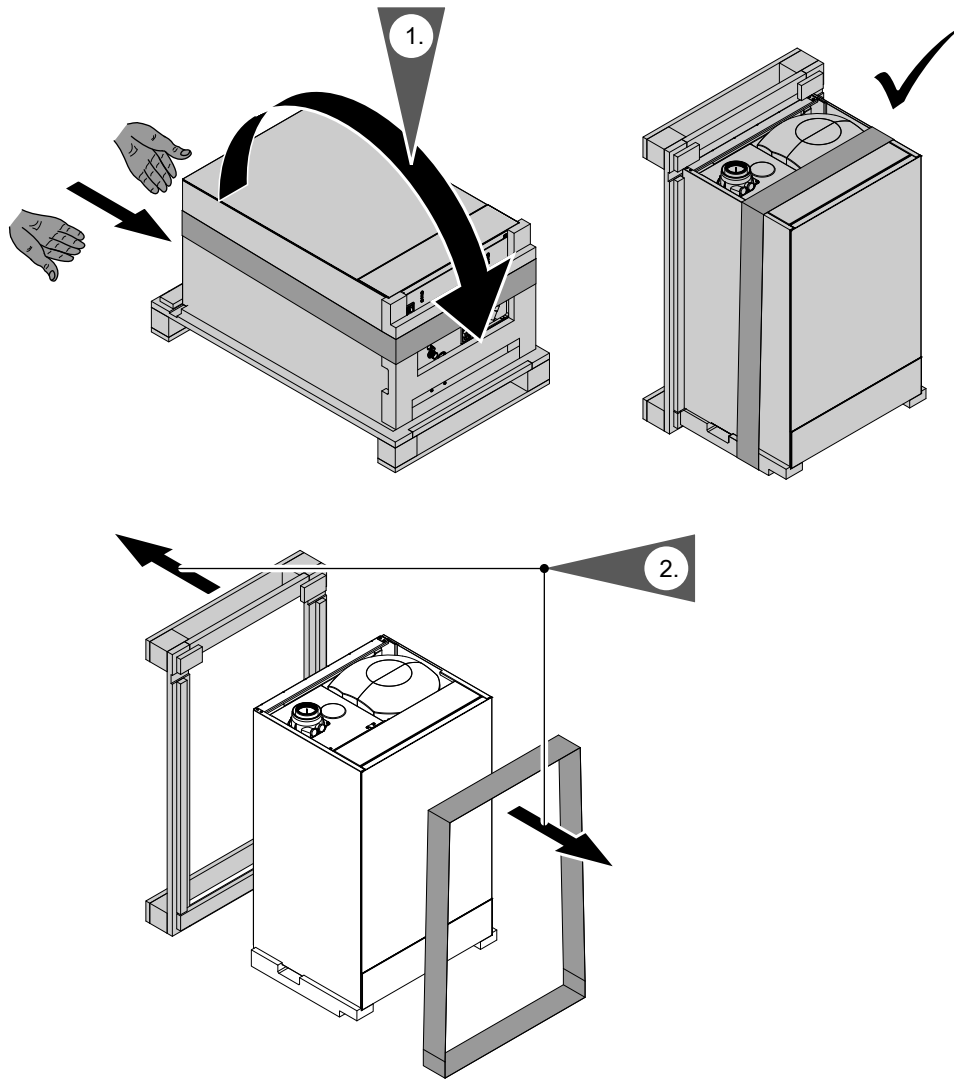

Fig. 3

Mounting the boiler and making connections

Mounting the boiler on the pre-plumbing jig or mounting frame

Note

Various installation components can be found in a separate pack on the front panel. Keep the installation components safe, as they will be required for later installation.

Mounting the boiler and making connections (cont.)

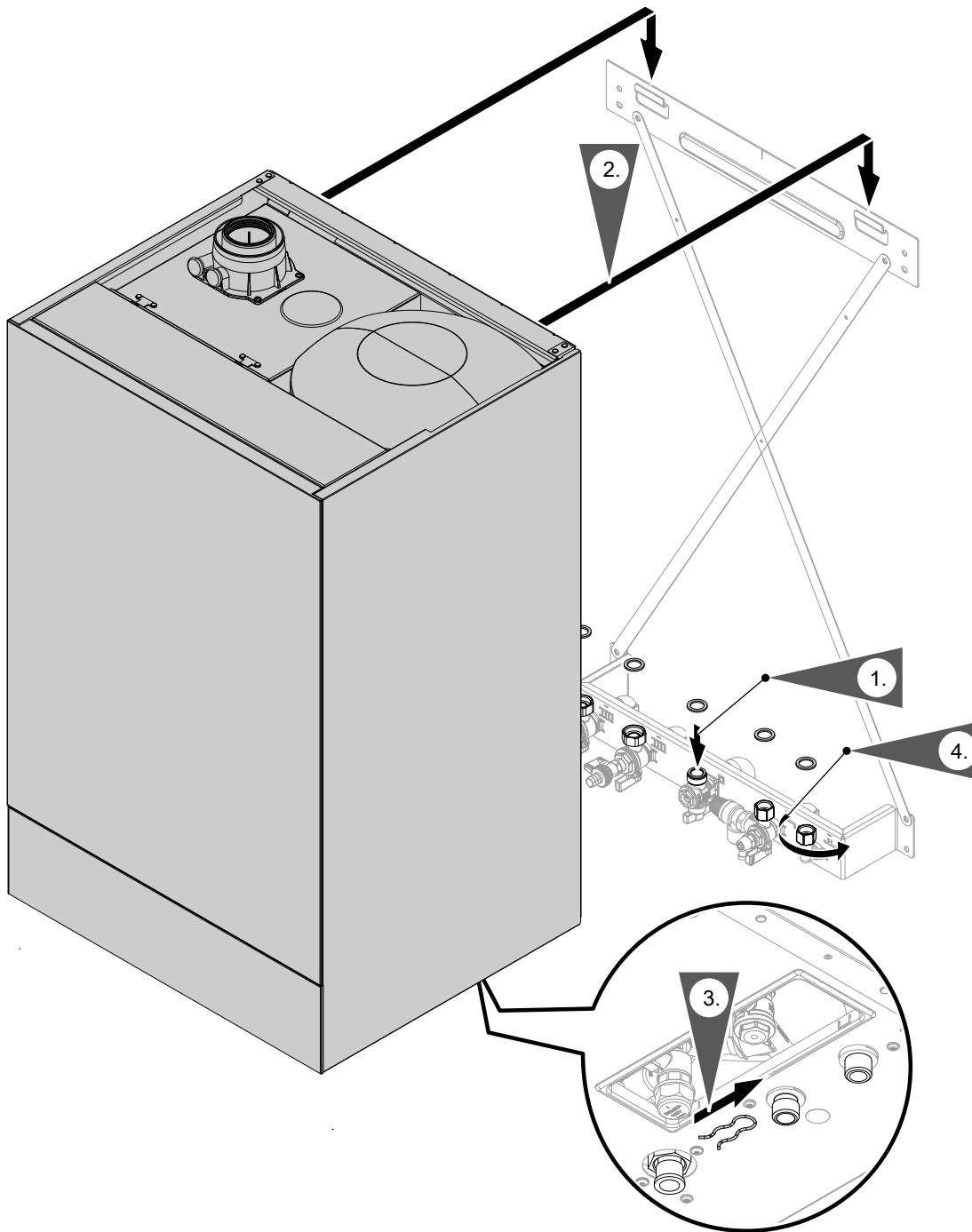

Fig. 4

Note

The diagram shows installation on a pre-plumbing jig.

The boiler can be installed on the following accessories:

- Pre-plumbing jig
- Pre-plumbing jig for sub-mounting kit
- Mounting frame

1. Replace gaskets.

Internal gasket diameter:

- Gas connection $\text{\O} 18.5 \text{ mm}$
- Connections on the heating water side $\text{\O} 17.0 \text{ mm}$

Note

Gasket for gas connection is attached to the gas shut-off valve.

2. **Note**

After mounting, ensure correct seating.

Mounting the boiler and making connections (cont.)

3. **Note**

Only remove the clip under the gas pipe union nut once the appliance has been installed. Clip is no longer required.

4. Tighten union nuts so that they form a tight seal. Tighten the union nuts as tightly as necessary and ensure that the components are undamaged and are functioning correctly throughout service life. Observe torque settings if a torque wrench is available.
Check for gas tightness to BSI 6891.

Torque for union nuts

- G ½: 24 Nm
- G ¾: 30 Nm

When carrying out any work on gas connection fittings, counterhold with a suitable tool. Never transfer any forces to the internal components.

Mounting the boiler and making connections (cont.)

Fitting the boiler to the wall mounting bracket

Note

Various installation components can be found in a separate pack. Keep the installation components safe, as they will be required for later installation.

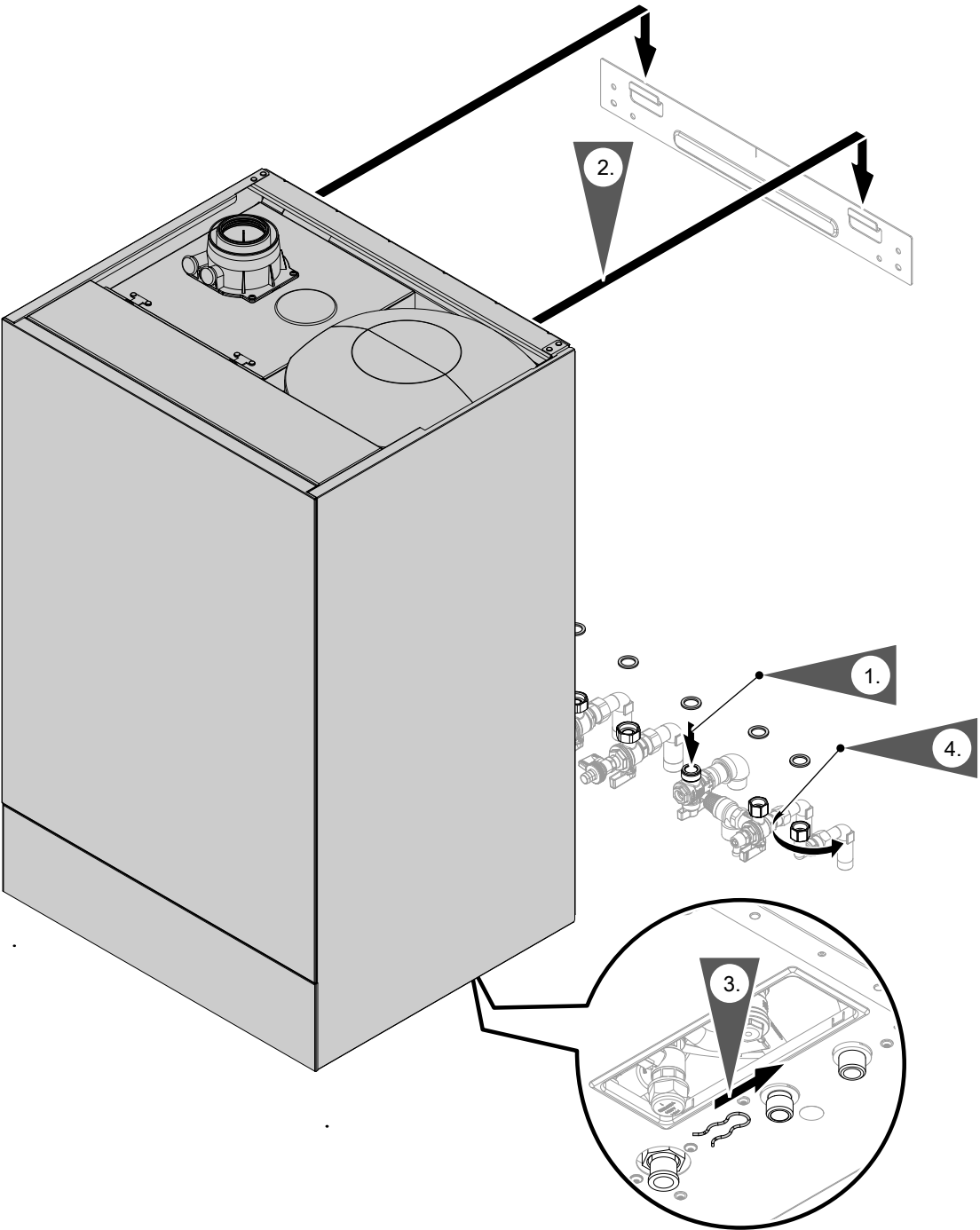

Fig. 5

Mounting the boiler and making connections (cont.)

1. Replace gaskets. Fit valves and gas shut-off valve.

Internal gasket diameter:

- Gas connection Ø 18.5 mm
- Connections on the heating water side Ø 17.0 mm

Note

Gasket for gas connection is attached to the gas shut-off valve.

2. Suspend the Vitodens from the wall mounting bracket.

3. **Note**

Only remove the clip under the gas pipe union nut once the appliance has been installed. Clip is no longer required.

4. Tighten union nuts so that they form a tight seal. Tighten the union nuts as tightly as necessary and ensure that the components are undamaged and are functioning correctly throughout service life. Observe torque settings if a torque wrench is available.

Check for gas tightness to BSI 6891.

Torque for union nuts

- G ½: 24 Nm
- G ¾: 30 Nm

When carrying out any work on gas connection fittings, hold with a suitable tool. Never transfer any forces to the internal components.

Mounting the boiler and making connections (cont.)

Removing the front panel

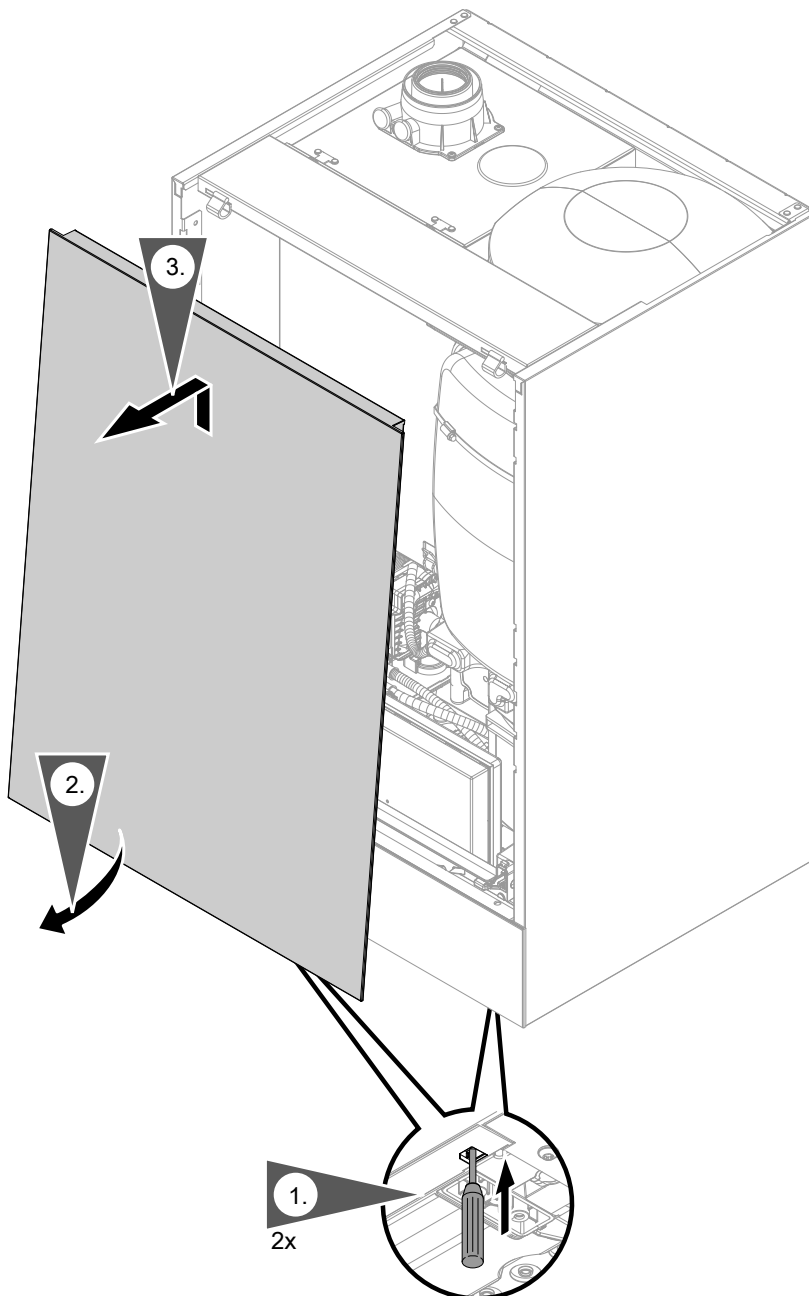

Fig. 6

Type plate

Note

The type plate is attached to cover panel (A) in the appliance. See page 41.

Additional type plate with access code (QR code) marked with "i"

The type plate of the heat generator contains extensive product information and an appliance-specific QR code marked with "i" for direct access to product-specific information and product registration on the internet.

The QR code contains the credentials for the registration and product information portal, and the 16-digit serial number.

Attaching the additional type plate

Installation sequence

Mounting the boiler and making connections (cont.)

1. Take the additional type plate from the documentation supplied with the boiler.

Note

The documentation with the additional type plate and QR code marked with "i" can be found on top of the appliance.

2. In consultation with the system user, affix the additional type plate to the outside of the appliance. The additional type plate must be visible to the flue gas inspector. Affix another QR code to the installation and service instructions.

Connections on the heating water and DHW sides

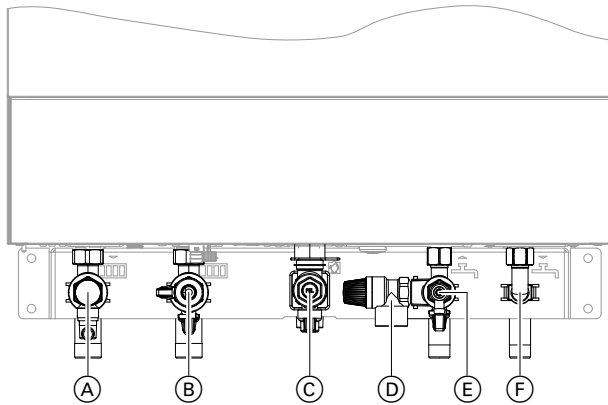

Fig. 7

- (A) Heating flow
- (B) Heating return and fill/drain valve

- (C) Gas connection
- (D) Safety valve
- (E) Cold water
- (F) DHW

If the connections have not been fitted previously, make the connections on the heating water and DHW sides.

The standard delivery contains connection accessories including locking ring fitting.

Condensate connection

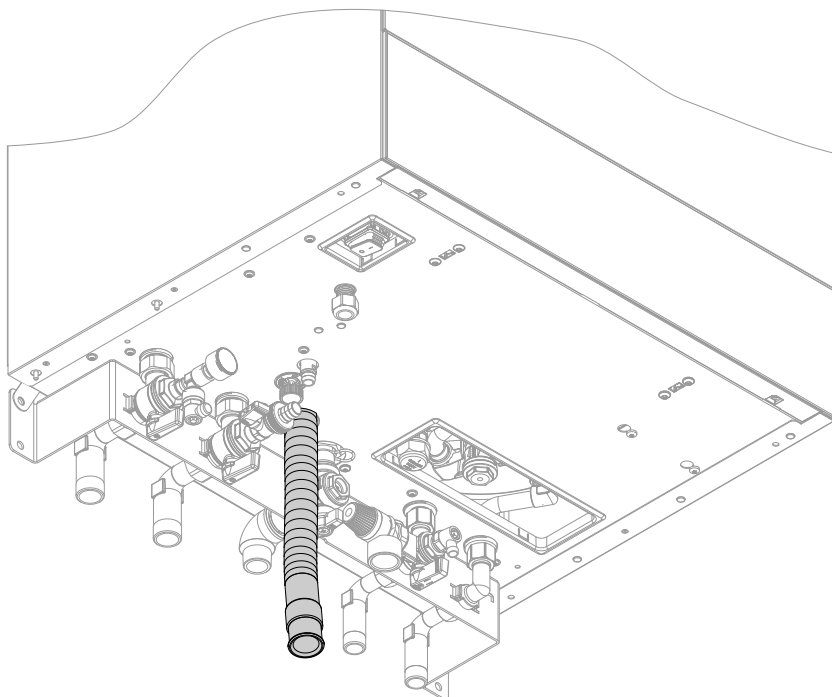

Fig. 8

Condensate connection (cont.)

Connect the drain hose with a constant fall and a pipe vent to the drain network or a neutralising system.

Note

Route the onward drain line inside the building as far as possible.

If the onward drain line is routed outside the building:

- Use a min. \varnothing 30 mm line.
- Protect the line from frost.
- Keep the line as short as possible.



Please note

The drain hose is used to route away any hot water discharged from the safety valve. Lay and secure the drain hose in a way that prevents any risk of scalding.

Note

Observe local waste water regulations.

Filling the trap with water

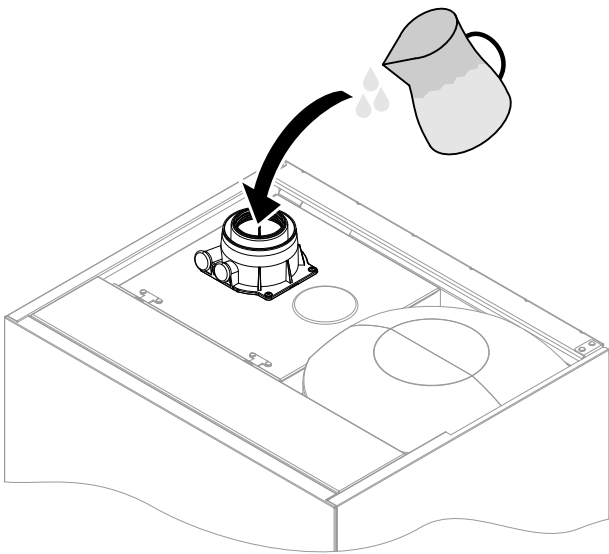

Fig. 9

Pour at least 0.3 l of water into the flue gas connection.



Please note

During commissioning, flue gas may escape from the condensate drain. Always fill the trap with water before commissioning.

Note

If there is a risk of frost, only fill the trap just before commissioning.

Flue gas connection

Note

The labels "System certificate" and "Skoberne GmbH or Groppalli flue system" enclosed with the technical documentation may only be used in conjunction with the Viessmann flue system made by Skoberne or Groppalli.



Connecting the balanced flue pipe
Flue system installation instructions

Flue gas connection (cont.)

Connecting several Vitodens to a shared flue system

If several Vitodens are connected to a common flue system: Install a back draught safety device (accessories) in the flue gas connection and in the mixing shaft of the burner on each boiler.

Note

Not all appliance types are approved for "multiple connection".

Please order Vitodens appliances that are suitable for this; see pricelist.

Note

In appliances for "multiple connection", a special back draught safety device is installed in the mixing shaft of the burner, downstream of the fan.

A further back draught safety device is installed in the flue system.

Installing the back draught safety devices:



Installation instructions for back draught safety device

Only carry out **commissioning** when the following conditions have been met:

- Unrestricted flow in the flue gas routes.
- Positive pressure flue system is gas-tight.
- Inspection port covers checked for secure and tight seating.
- Apertures for supplying sufficient combustion air are open and cannot be closed.
- All current regulations on installing and commissioning flue systems have been observed.



Danger

Leaking or blocked flue systems, or an inadequate supply of combustion air can cause life threatening poisoning from carbon monoxide in the flue gas.

Ensure the flue system is in good working order. Vents for supplying combustion air must be non-sealable.

Prevent condensate drainage via a wind protector.

Gas connection

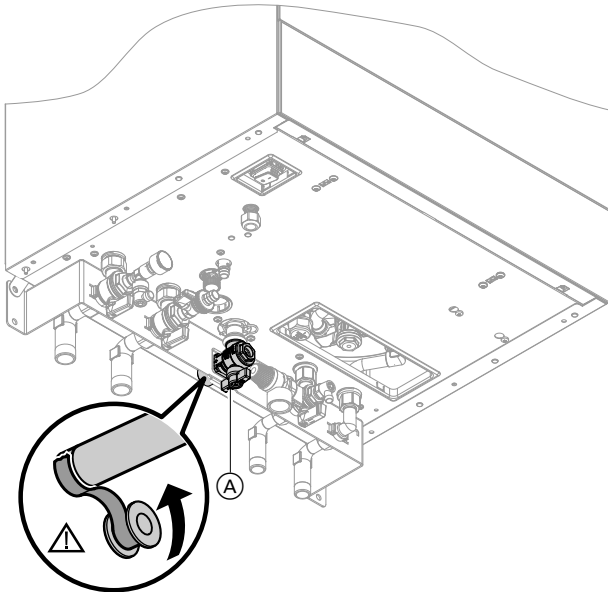

Fig. 10

1. If the gas connection has not been fitted previously, seal gas shut-off valve (A) to the gas connection.
When carrying out any work on gas connection fittings, counterhold with a suitable tool. Never transfer any forces to the internal components.
3. Purge the gas line.

Information on operation with LPG

Install an external safety solenoid valve if the boiler is installed below ground level.

An EM-EA1 extension (accessories) is required to connect the safety solenoid valve.

2. Check for leaks.



Danger

Escaping gas leads to a risk of explosion. Check all connections on the gas side (also inside the appliance) for tightness.

Note

Only use suitable and approved leak detection agents (EN 14291) and devices for the tightness test. Leak detection agents with unsuitable constituents (e.g. nitrides, sulphides) can cause material damage.

Remove residues of the leak detection agent after testing.



Please note

Excessive test pressure will damage the boiler and gas solenoid valve. Max. test pressure 150 mbar (15 kPa). If a higher pressure is required for leak tests, disconnect the boiler and the gas solenoid valve from the main supply pipe (undo the fitting).

Gas connection (cont.)

Gas installation to BS 6891:2005

It is the gas installer's responsibility to size the gas installation lines in accordance with BS 6891:2005. If it is determined that the operating pressure falls below the minimum outlet level for the measuring device of 19 MB, it should be checked to ensure that the gas pressure is sufficient for correct and safe operation.

Taking into account a pressure drop from the installation lines of no more than 1 MB, it can be assumed that a permissible minimum pressure of 18 MB is present at the appliance's gas connection (reference BS 6400-1 Section 6.2, Pressure absorption).

The external gas tap may reduce operating pressure further if measured at its test point. The pressure drop is relative to the heat input of the boiler (kW). Observe minimum gas pressure at the gas fitting in accordance with the table – see page 42

Electrical connections

- !** **Please note**
Electronic assemblies can be damaged by electrostatic discharge.
Prior to commencing any work, touch earthed objects, such as heating or water pipes to discharge static loads.

Opening the wiring chamber

Note

If only PlusBus and the outside temperature sensor are connected to the boiler, the wiring chamber does not need to be opened.

Electrical connections (cont.)

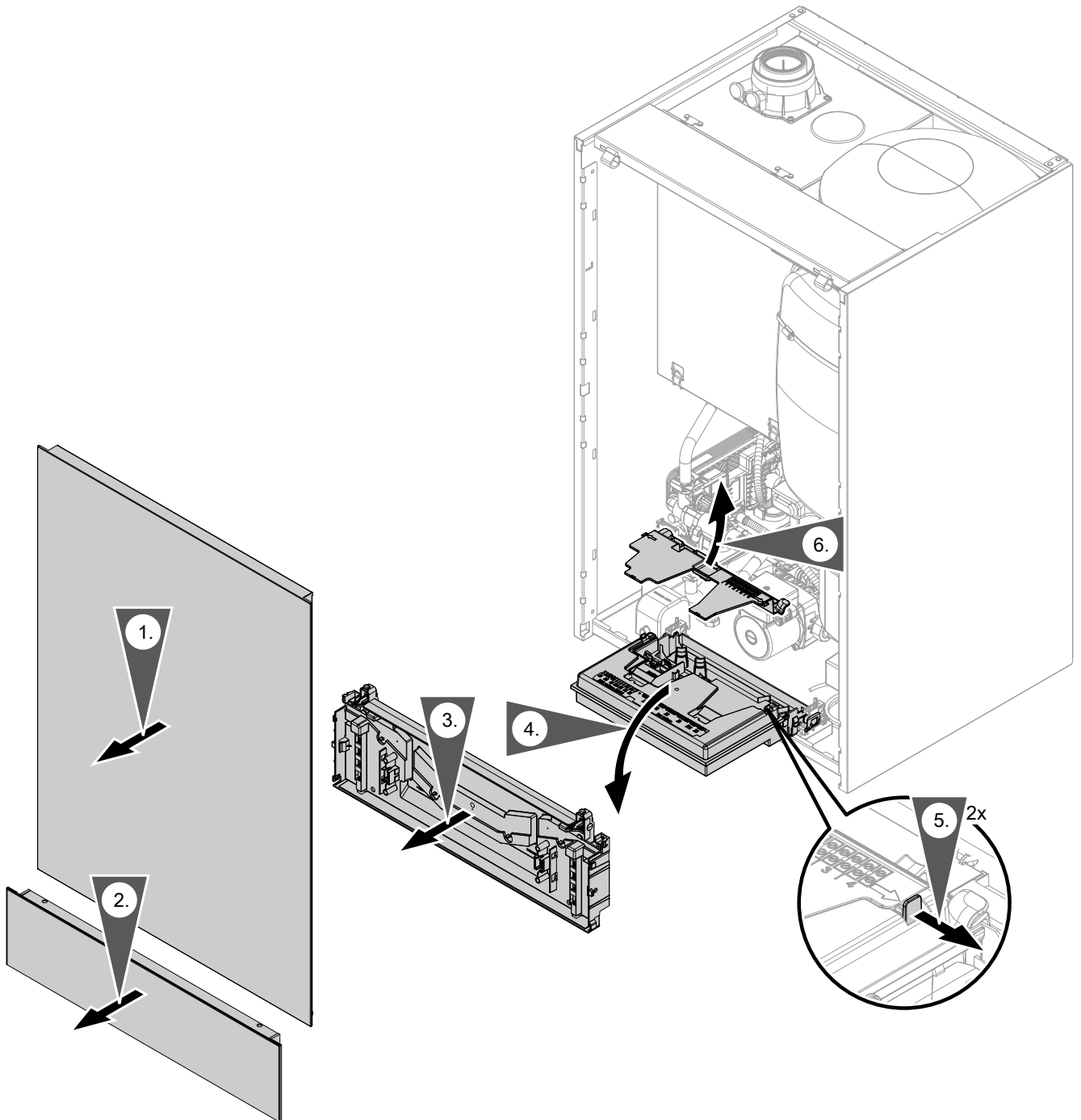

Fig. 11

Note

Do not disconnect the plug from the mounting panel.
Do not change the position of the cable or its fixture
(fixing point on casing).

Layout of the electrical connections**Note**

For further information on the connections, see the following chapters.

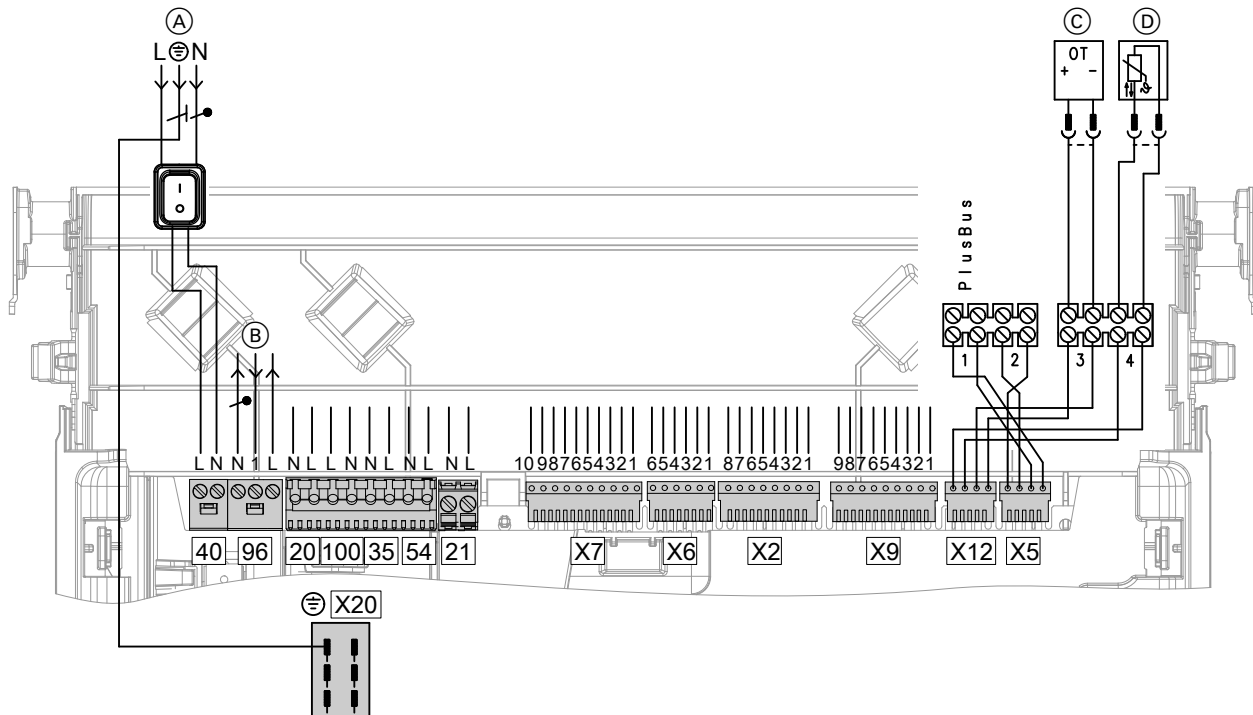

Fig. 12

Connections to 230 V~ plugs

- (A) Power supply [40]
- (B) Configurable floating input [96], 230 V
230 V output
230 V room thermostat connection
- [20] Heating circuit pump
- [100] Fan motor
- [35] Gas solenoid valve
- [54] Ignition unit/ionisation

- [21] Cylinder loading pump
- (C) Remote control (OpenTherm device)
- (D) Outside temperature sensor
- X[20] Equipotential bonding (earth conductor)



Note on connecting accessories

When connecting accessories observe the separate installation instructions provided with them.

Electrical connections (cont.)

On-site connections on the HMBU heat management unit

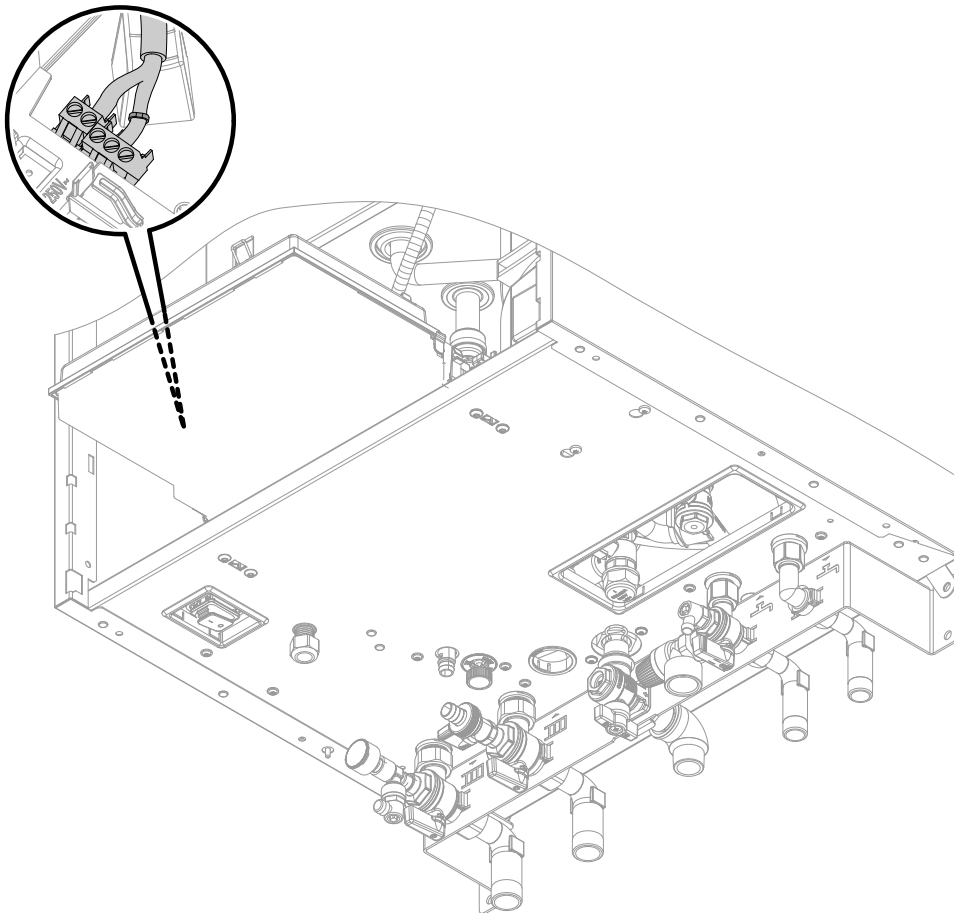

Fig. 13

- (A) Plug-in connection on underside of appliance
- (B) Plug for connecting sensors and PlusBus
Remove plug from the pack of installation components.
- (C) Aperture for cable entry

Required plugs are supplied in separate packaging.

For cables without strain relief bushings, provide strain relief in the wiring chamber in the form of cable ties.

Outside temperature sensor

Fitting location for outside temperature sensor

- North or north-westerly wall, 2 to 2.5 m above ground level; in multi storey buildings, in the upper half of the second floor
- Not above windows, doors or vents
- Not immediately below balconies or gutters
- Never render over

Outside temperature sensor connection

See page 23
2-core lead, length up to 35 m with a cross-section of 1.5 mm²

Floating switching contact connection

Connection at plug 96

One of the following functions can be connected:

- "0" No function or room thermostat
- "2" DHW circulation pump external demand (push-button function, pump runs for 5 min). Not for Vitodens 111-W

Electrical connections (cont.)

- "4" External demand
- "5" External blocking or alternatively connection for external heating circuit hook-up (if no more than one heating circuit hook-up is configured on commissioning. If more than one heating circuit hook-up is required, connect to EM-EA1 accessory)

Assigning functions in the commissioning assistant

See commissioning assistant in "Commissioning".

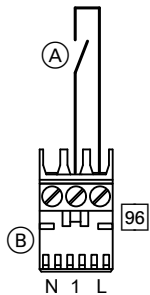

Fig. 14

- (A) Floating contact
- (B) Plug 96

Notes on connecting PlusBus subscribers

As a maximum, the following PlusBus subscribers can be connected to the control unit (terminal 1):

- One EM-M1 or EM-MX extension
- One Vitotrol 200-E
- One EM-EA1 extension
- One EM-S1 extension
- One EM-P1 extension

Note

The number of PlusBus subscribers is limited: Max. one Vitotrol 200-E plus a maximum of 3 additional extensions, e.g. EM-M1 or EM-EA1.

Example: 1 x Vitotrol 200-E + 1 x EM-M1 + 1 x EM-EA1.

If no Vitotrol 200-E is connected, 4 extensions can be connected.

The max. total length of the PlusBus lead is 50 m. With an unscreened lead, 2-core, 0.34 mm².

Accessories mains connection, connect plug to external power supply

Connect one or more extensions via an ON/OFF switch directly to the mains supply (see next chapter).

Accessories with direct mains connection

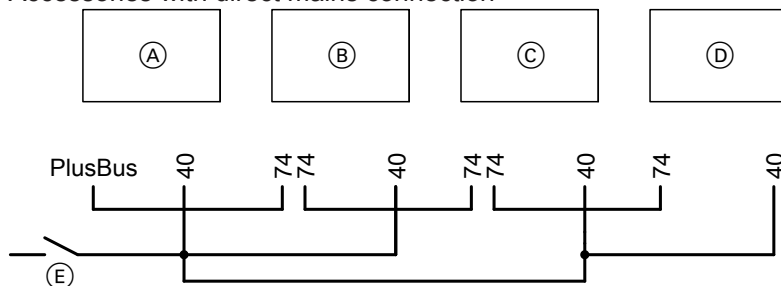

Fig. 15

- (A) HBMU heat management unit, heat generator
- (B) Mixer extension kit
- (C) EM-EA1 extension and/or EM-S1 extension
- (D) EM-P1 extension
- (E) External ON/OFF switch
- 40 Mains input
- 74 PlusBus

Electrical connections (cont.)

Note

PlusBus system length max. 50 m for 0.34 mm² cable cross-section and unshielded cable.

If the current flowing to the connected working parts (e.g. circulation pumps) is higher than the fuse rating of the relevant accessory, only use the output concerned to control an on-site relay.

Note

Use addressing for rotary selector S1. See also the information in chapter "Notes on connecting PlusBus subscribers".

Accessories	Internal fuse protection
EM-M1, EM-MX mixer extension kit	2 A
EM-EA1 extension	2 A
EM-S1 extension (not for Vitodens 111-F)	2 A



Danger

Incorrect wiring can lead to serious injury from electrical current and result in appliance damage.

- Route extra low voltage (ELV) leads < 42 V separately from cables > 42 V/230 V~.
- Strip as little of the insulation as possible, directly before the terminals, and bundle close to the corresponding terminals.
- Secure cables/leads with cable ties.

Power supply 40



Danger

Incorrectly executed electrical installations can result in injuries from electrical current and damage to the appliance.

Connect the power supply and implement all safety measures (e.g. RCD circuit) in accordance with the following regulations:

- IEC 60364-4-41
- IEEE Wiring Regulation; BS 7671:2018
- Connection conditions of the local grid operator

- Install an isolator in the power cable to provide omnipolar separation from the mains for all active conductors, corresponding to overvoltage category III (3 mm) for complete isolation. The isolator must be fitted in the permanent electrical installation, in line with installation requirements.

We also recommend installing a pulse current-sensitive RCD (RCD class A).

- Connect the power cable to the electricity supply using a fixed connection.

- If the power supply to the appliance is connected with a flexible power cable, ensure that the live conductors are pulled taut before the earth conductor in the event of strain relief failure. The length of the earth conductor wire will depend on the design.
- Max. fuse rating 16 A.



Danger

The absence of system component earthing can lead to serious injury from electric current if an electrical fault occurs.

The appliance and pipework must be connected to the equipotential bonding of the building.

Routing connecting cables/leads



Please note

If connecting cables/leads come into contact with hot components, they will be damaged. When routing and securing cables/leads on site, ensure that the maximum permissible temperatures for these cables/leads are not exceeded.

Electrical connections (cont.)

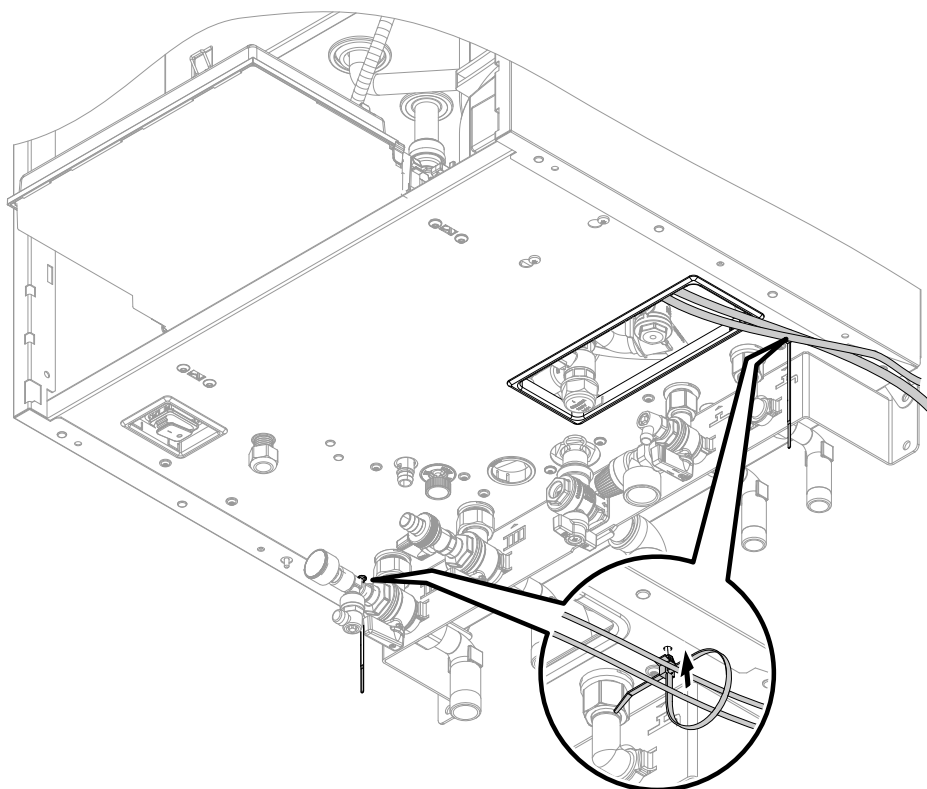

Fig. 16

Bundle cables using the supplied cable ties. Secure the cable ties to the underside.
Do not route cables/leads over sharp edges and lying against the casing (sound transmission).

WiFi operational reliability and system requirements

WiFi router system requirement

- WiFi router with activated WiFi:
The WiFi router must be protected by a sufficiently secure WPA2 password.
The WiFi router must always have the latest firmware update.
Do not use unencrypted connections between the heat generator and the WiFi router.
- Internet connection with high availability:
Flat rate (flat rate tariff **without** restriction on time or data volume)

- Dynamic IP addressing (DHCP, delivered condition) in the network (WiFi):
Have this checked on site, and if required set up, by an IT expert **prior to** commissioning.
- Set routing and security parameters in the IP network (LAN):
Enable port 80, port 123, port 443 and port 8883 for direct outward connections.
Have this checked and, if necessary, set up on site by an IT expert **before** commissioning.

Wireless signal range of WiFi connection

The range of wireless signals may be reduced by walls, ceilings and interior fixtures. These weaken the wireless signal, causing poor reception due to the following circumstances.

- On their way between transmitter and receiver, wireless signals are **damped**, e.g. by air or when penetrating walls.
- Wireless signals are **reflected** by metallic objects e.g. reinforcements embedded in walls, metal foil of thermal insulation and thermal glazing with metalised thermal vapour deposit.

WiFi operational reliability and system... (cont.)

- Wireless signals are **isolated** by service ducts and lift shafts.
- Wireless signals are **disrupted** by devices that also operate with high frequency signals. Maintain a distance of **at least 2 m** from these devices:
 - Computers
 - Audio and video systems
 - Devices with active WiFi connection
 - Electronic transformers
 - Pre-ballasts

Install the heat generator as close as possible to the WiFi router to ensure a good WiFi connection. The signal strength can be displayed on the heat generator (see the operating instructions).

Note

The WiFi signal strength can be increased with commercially available WiFi repeaters.

Angle of penetration

The reception quality remains best if radio signals hit the walls vertically. Depending on the angle of penetration, the effective wall thickness changes and so does the extent to which the electromagnetic waves are damped.

Flat (unfavourable) angle of penetration

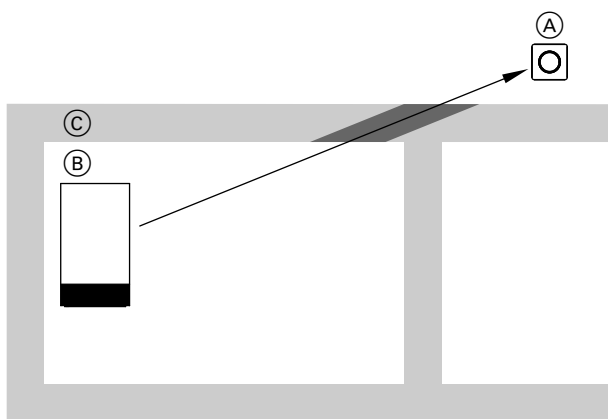

Fig. 17

- Ⓐ WiFi router
- Ⓑ Heat generator

- Ⓒ Wall

Ideal angle of penetration

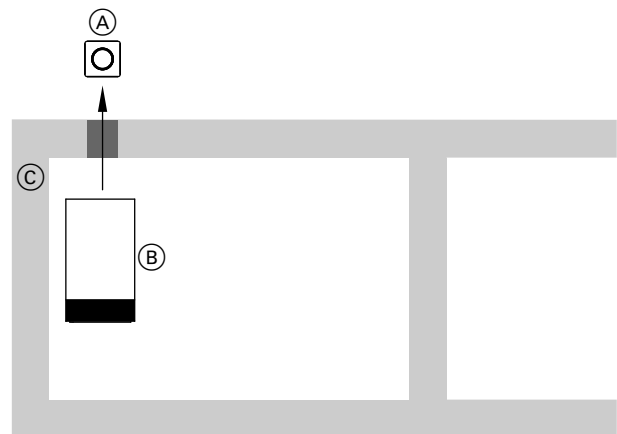

Fig. 18

- Ⓐ WiFi router
- Ⓑ Heat generator
- Ⓒ Wall

Closing the wiring chamber and fitting the front panel

Installation

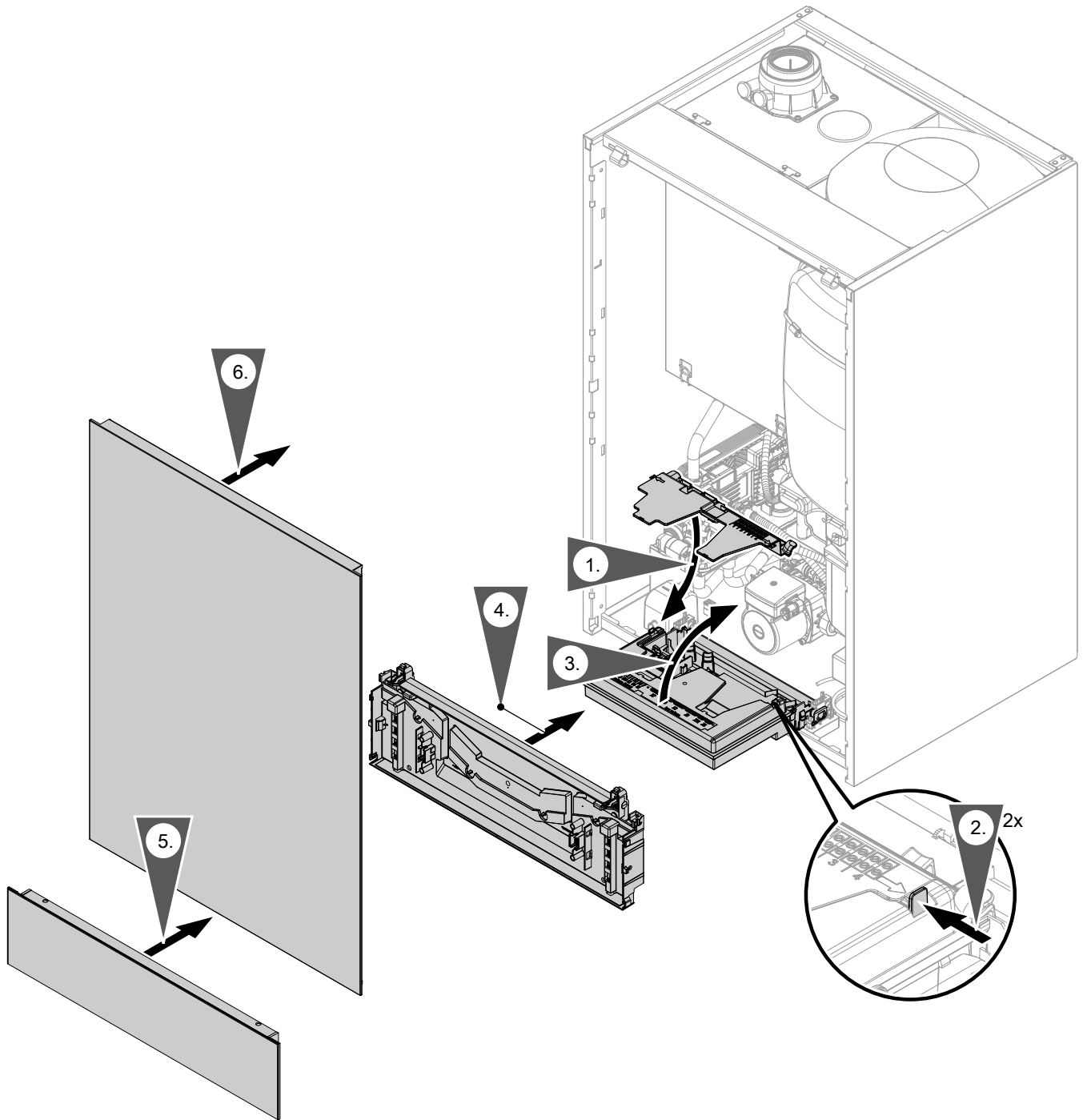

Fig. 19



Steps - commissioning, inspection and maintenance

				Page
			Commissioning steps	
			Inspection steps	
			Maintenance steps	
•			1. Commissioning the system with the commissioning assistant.....	32
•	•		2. Filling the heating system.....	36
•			3. Filling the loading cylinder on the DHW side.....	38
•	•	•	4. Checking all connections on the heating water and DHW sides for leaks.....	38
•			5. Venting the heating system.....	38
•			6. Checking the gas type.....	39
•			7. Converting the gas type for operation with LPG.....	39
•	•	•	8. Removing the front panel.....	40
•	•	•	9. Checking the static pressure and supply pressure.....	41
•			10. Function sequence and possible faults.....	42
•			11. Setting the max. heating output.....	43
•	•	•	12. Performing an actuator test.....	44
•			13. Adjusting pump rate of integral circulation pump.....	44
•			14. Activating screed drying.....	45
•			15. Leak test on balanced flue system (annular gap check).....	46
•			16. Burner adjustment when connecting multiple flues to a shared flue system.....	46
•	•	•	17. Removing the burner.....	46
•	•	•	18. Checking the burner gasket and burner gauze assembly.....	48
•	•	•	19. Checking and adjusting the ignition and ionisation electrodes.....	49
•	•	•	20. Checking the back draught safety devices.....	49
•	•	•	21. Cleaning the heating surfaces.....	50
•	•	•	22. Checking the condensate drain and cleaning the trap.....	51
•	•	•	23. Installing the burner.....	52
•	•	•	24. Checking the neutralising system (if installed)	
•	•	•	25. Checking the expansion vessel and system pressure.....	53
•	•	•	26. Checking the DHW expansion vessel (if installed) and the pre-charge pressure.....	54
•	•	•	27. Checking the safety valve function	
•	•	•	28. Checking the electrical connections for firm seating	
•	•	•	29. Checking all gas equipment for leaks at operating pressure.....	55
•	•	•	30. Fitting the front panel.....	55
•	•	•	31. Checking the combustion quality.....	55
•	•	•	32. Checking the flue system for unrestricted flow and leaks	
•	•	•	33. Checking the external LPG safety valve (if installed)	
•			34. Matching the control unit to the heating system.....	56
•			35. Adjusting the heating curves.....	57
•			36. Instructing the system user.....	57





! Please note
 Only commission the appliance with a fully filled trap.
 Check that the trap has been filled with water.

! Please note
 Only commission the appliance with a fully filled trap.
 Check that the trap has been filled with water.

Commissioning via commissioning assistant

1. Open the gas shut-off valve.
2. If the appliance has not yet been switched on:
 1. Turn on the ON/OFF switch.
 2. **AP** and appear on the display.
 3. Press menu button and hold for 4 s. The commissioning assistant starts automatically.
 If the appliance has already been switched on, you can call up the commissioning assistant yourself:
 1. and **OK** should be pressed simultaneously for approx. 4 s.
 2. Use / to select "**b.5**" and confirm with "**OK**".

Note
*AP and appear on the display. Confirm with **OK** to start the connection with the software tool: see chapter "Commissioning via software tool".*

3. – press for 4 s to start the commissioning assistant.

3. For further steps, see commissioning assistant in the following overview.

Commissioning via software tool

Note
Apps for commissioning and service are available for iOS and Android devices.



1. Open the gas shut-off valve.
2. **AP** and appear on the display. Press **OK** and enter the password for the heat generator to carry out commissioning with the software tool.
3. Select **ON** and confirm with **OK**.
4. Follow the instructions in the software tool.





Commissioning assistant sequence	Explanations and references
Commissioning	
"C.1" Filling program	ON = on OFF = off Note <i>It is possible to interrupt or end the process while a rotating rectangle alternating with the current system pressure is displayed; to do so, press and hold ≡ for 3 s.</i>
"C.2" Venting program	ON = on OFF = off Note <i>It is possible to interrupt or end the process while a rotating rectangle alternating with the current system pressure is displayed; to do so, press and hold ≡ for 3 s.</i>
"C.3" Gas type	2 - Natural gas 3 - Liquid gas LPG
"C.5" Flue system	1 - Open flue 60 mm 2 - Room sealed 60/100 mm 3 - Open flue 80/125 mm 4 - Room sealed 80/125 mm
"C.6" Flue length	Given in full metres (round up if necessary) Note <i>An additional length of 1 m must be factored in for every flue bend.</i>
"C.7" Operating mode	1 - Constant operation with time program 4 - Weather-compensated 13 - Constant operation with optional room thermostat 14 - OpenTherm 15 - Individual room control 16 - Individual room control with modulation Note <i>Operating modes 15 and 16 can only be set via the software tool.</i>





Commissioning assistant sequence	Explanations and references
<p>"C.8" System scheme (depending on appliance type, not all schemes possible)</p>	<p>1 - 1 direct heating circuit without low loss header 2 - 1 direct heating circuit with low loss header 3 - 1 direct heating circuit without low loss header with DHW cylinder 4 - 1 direct heating circuit with low loss header and DHW cylinder upstream of low loss header 5 - 1 direct heating circuit + 1 heating circuit with mixer and low loss header + DHW cylinder 6 - 1 direct heating circuit with low loss header + DHW cylinder upstream of low loss header + solar DHW cylinder 7 - 1 direct heating circuit + 1 heating circuit with mixer and low loss header + DHW cylinder upstream of low loss header + solar DHW cylinder 8 - 1 direct heating circuit + 1 heating circuit with mixer and low loss header 9 - 1 heating circuit with mixer and low loss header + DHW cylinder upstream of low loss header 10 - 1 direct heating circuit without low loss header + DHW cylinder + solar DHW cylinder</p> <p>Note <i>System schemes 11 - 18 and the DHW circulation pump can be set via the software tool.</i></p> <p>11 - 1 heating circuit with mixer without low loss header 12 - 1 heating circuit with mixer with low loss header 13 - 1 heating circuit with mixer without low loss header + DHW cylinder 14 - 1 direct heating circuit + 1 heating circuit with mixer without low loss header + DHW cylinder 15 - 1 heating circuit with mixer with low loss header + DHW cylinder + solar DHW cylinder 16 - 1 heating circuit with mixer without low loss header + DHW cylinder + solar DHW cylinder 17 - 1 direct heating circuit + 1 heating circuit with mixer without low loss header + DHW cylinder + solar DHW cylinder 18 - 1 direct heating circuit + 1 heating circuit with mixer without low loss header</p> <p>Note <i>If a DHW circulation pump has been configured via the software tool, it is shown with a "C" after the system scheme number.</i></p>
<p>"C.9" External heating circuit hook-up</p>	<p>Note <i>Only for weather-compensated operation.</i></p> <p>0 - No external heating circuit hook-up 1 - External heating circuit hook-up HC1 2 - External heating circuit hook-up HC2 3 - External heating circuit hook-up HC1 and HC2 (EM-EA1 extension (DIO) required)</p>



Commissioning assistant sequence	Explanations and references
<p>"C.10" EM-EA1 (DIO) function</p> <p>Note If "C.9" is set to 3, then no setting is required at "C.10".</p>	0 - No function 4 - External set flow temperature 0-10 V 5 - External default output 8 - 230 V fault message input and fault message output (without system blocking) 10 - External extractor (e.g. cooker hood) 11 - Operating mode changeover 14 - Fault message input (24 V) and system blocking (e.g. condensate lift pump) 16 - External LPG valve 17 - 230 V fault message input and system blocking 18 - External demand (digital) 19 - External blocking
<p>"C.11" Date (day, month, year)</p>	
<p>"C.12" Time (hours, minutes)</p>	
<p>"C.13" Autom. summer/wintertime changeover</p>	ON = on OFF = off
<p>"C.14" Plug 96 function</p>	0 - No function 2 - External demand DHW circulation pump 4 - External demand 5 - External blocking If only one HC was configured with external hook-up, plug 96 setting is automatically applied. No selection or other function is then possible.
<p>"C.15" Remote control</p>	Off - not installed ON - Vitotrol 200-E with subscriber number 1 installed (all installed heating circuits can be controlled via the Vitotrol 200-E)
	After the final setting (C.15) has been completed, "End" appears on the display. Confirm with "OK" . The commissioning is started, the flue temperature sensor test is launched and "Fst" appears on the display.
Maintenance	
Interval in burner hours run until next maintenance	Can be adjusted via the software tool (notification also via software tool)
Interval until next maintenance	Can be adjusted via the software tool (notification also via software tool)
The system carries out a restart.	

Automatic flue gas temperature sensor check

The display shows: **"Err"**

If the flue gas temperature sensor is not positioned correctly, fault message 416 appears.

For further details regarding the flue gas temperature sensor test, see "Repairs".

If fault message 416 appears, reposition the flue gas temperature sensor in the flue gas connection. Check for leaks on the flue gas side.

Note

The burner remains locked out until the test has been passed.

When the fault has been remedied, turn the ON/OFF switch off and back on again.



Switching WiFi ON/OFF

The appliance is equipped with an integrated WiFi communication module with extended type plate. The internal communication module supports commissioning of the heat generator with the "Vitoguide app", connectivity with the "ViCare app" and the connection to the "Vitoguide" digital service centre. The access details required for establishing a connection are recorded in the form of an access code with "WiFi symbol". Three copies of this code are located on the rear of the programming unit.

Before installing the programming unit, remove the access code labels from the rear. For commissioning, affix one label to the space marked out on the type plate.

Switch on the WiFi connection and establish a connection to the router; see also page 28.

Note

If "E10" is displayed, the connection to the home network could not be established. Check the router and the network password.

If "E12" is displayed, the connection to the server could not be established. Re-establish the connection at a later time.

Activating the internet connection:

 Operating instructions



Affix a further credentials label here, so it can be found for subsequent use:



Fig. 20

Affix a label in the operating instructions.

Note



If the communication module is to be switched on or off, press   simultaneously for 4 s.

Calling up the commissioning assistant at a later point

If you need to continue commissioning later, the commissioning assistant can be reactivated at any time.

Tap the following buttons:

1.  and **OK** simultaneously for approx. 4 s, then release.

2. Use   to select "b.5" and confirm with "OK". For further steps, see the commissioning assistant.



Filling the heating system

According to EN 1717, as a heat transfer medium for DHW heating, the heating water must meet fluid category ≤ 3 . This requirement is met if water of potable quality is used as heating water. For example, if additives are used, the additive manufacturer must specify which category the treated heating water comes under.



Please note

Unsuitable fill water increases the level of deposits and corrosion and may lead to appliance damage.

- Flush the heating system thoroughly before filling.
- Only fill with water of potable quality.
- Fill water with a hardness above 300 ppm must be softened.
- Special antifreeze suitable for heating systems can be added to the fill water. The antifreeze manufacturer must verify its suitability.



Filling the heating system (cont.)

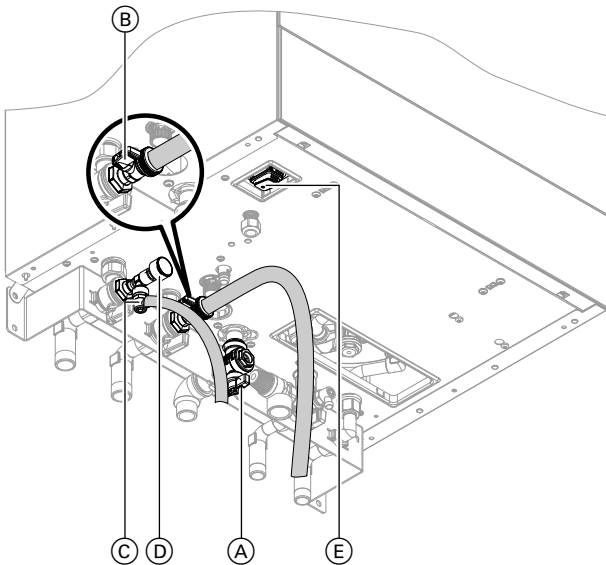

Fig. 21

(E) ON/OFF switch

1. Check the pre-charge pressure of the expansion vessel.
 2. Close gas shut-off valve (A).
 3. Activate the filling function (see commissioning assistant or following chapter).
 4. Fill the heating system at boiler drain & fill valve (B) in the heating return (on the connection set or on site). Minimum system pressure > 1.0 bar (0.1 MPa). Check the system pressure at pressure gauge (D). The indicator must be in the green band. If necessary, open the on-site air vent valve.
- Note**
Ensure that the safety valve does not respond when you are filling the system. If the flow rate through the safety valve becomes too high, water may enter the combustion chamber.
5. Fit hose to air vent valve (C). Route the hose into a suitable container or drain outlet.
 6. Close the shut-off valves on the heating water side.
 7. Open air vent valve (C) and fill valve (B) in the heating return. Vent (flush) under mains pressure until no more air noise is audible.
 8. Close air vent valve (C) and boiler drain & fill valve (B). Check the system pressure at pressure gauge (D). The indicator must be in the green band.
 9. Open the shut-off valves on the heating water side.

Activating the filling function

If the filling function is to be activated after commissioning.

Tap the following buttons:

1. and **OK** simultaneously for approx. 4 s, then release.
2. Use to select "b.5" for the commissioning assistant.
3. **OK**
4. The display shows "AP". Press for 4 s.
5. Use to select "C.1" for the filling function.
6. **OK**
7. to select "ON" for filling.
8. **OK**
 The filling function is activated. The display shows the current system pressure. The filling function ends automatically after 20 min or when you tap **OK**.



Filling the loading cylinder on the DHW side

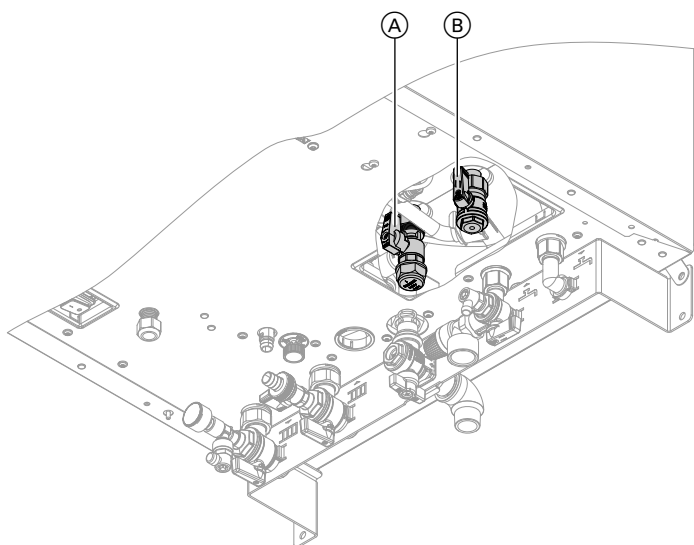

Fig. 22

1. Valves (A) and (B) must be in the "top" position.
2. Open the cold water line and a DHW draw-off point.
3. Once air stops coming out of the DHW draw-off point, the loading cylinder is completely filled.



Checking all connections on the heating water and DHW sides for leaks



Danger

Risk of electric shock from escaping heating water or DHW.

When commissioning and after carrying out maintenance work, check all water side connections for leaks.



Venting the heating system

1. Check whether the air vent screw in quick-action air vent valve (A) of the heating circuit pump is open.
2. Close the gas shut-off valve. Switch the appliance on.
3. Activate venting function (see following steps).
4. Call up the pressure display with "System overview". Check the system pressure.

Activating the venting function

If the venting function is to be activated after commissioning.

Tap the following buttons:

1. and **OK** simultaneously for approx. 4 s, then release.
2. Use to select "b.5" for the commissioning assistant.
3. **OK**
4. The display shows "AP". Press for 4 s.
5. Use to select "C.2" for ventilation.
6. **OK**
7. should be used to select "ON" to switch on the ventilation.



Venting the heating system (cont.)

8. OK

The venting function is activated. The display shows the current system pressure.

The venting function ends automatically after 20 min or when you tap **OK**.



Checking the gas type

The boiler is equipped with an electronic combustion controller that adjusts the burner for optimum combustion in accordance with the prevailing gas quality.

- For operation with natural gas, no adjustment is therefore required across the entire Wobbe index range. The boiler can be operated within the Wobbe index range 9.5 to 15.2 kWh/m³ (34.2 to 54.7 MJ/m³).
- For operation with LPG, the gas type needs to be changed on the control unit (see following chapter).

1. Determine the gas type and Wobbe index by asking your local gas supply utility or LPG supplier.
2. Record the gas type in the service report.



Converting the gas type for operation with LPG

1. To change the gas type on the control unit, see "Commissioning the system with the commissioning assistant"

2. Affix label "G31" (supplied with the technical documentation) adjacent to the type plate on the cover panel.

Note

No mechanical adjustments are made to the gas solenoid valve.





Removing the front panel

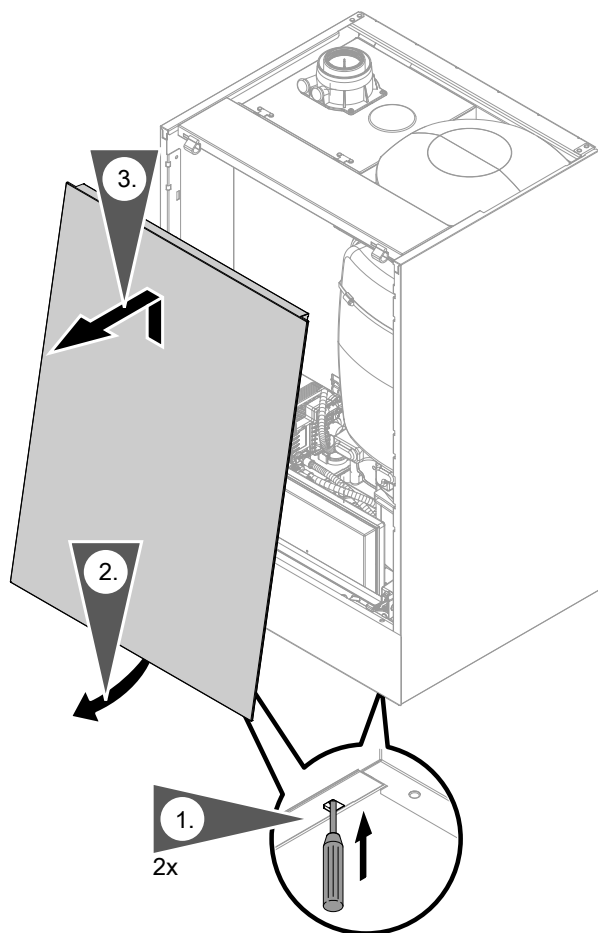
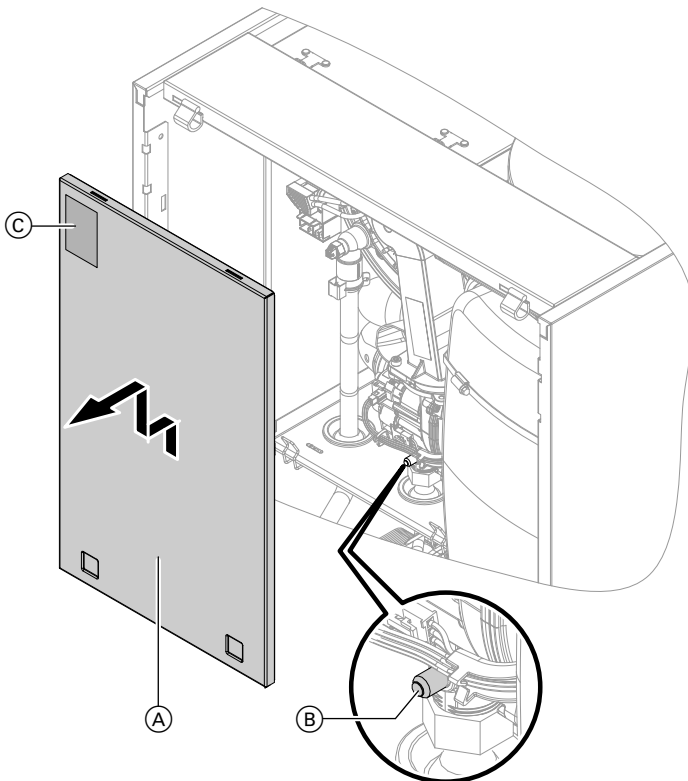

Fig. 23



Checking the static pressure and supply pressure



Danger

CO formation as a result of incorrect burner adjustment can have serious health implications. Carry out a CO test before and after work on gas appliances.

Fig. 24

- (A) Cover panel
- (C) Type plate

Gas installation to BS 6891:2005

It is the gas installer's responsibility to size the gas installation lines in accordance with BS 6891:2005. If it is determined that the operating pressure falls below the minimum outlet level for the measuring device of 19 MB, it should be checked to ensure that the gas pressure is sufficient for correct and safe operation.

Taking into account a pressure drop from the installation lines of no more than 1 MB, it can be assumed that a permissible minimum pressure of 18 MB is present at the appliance's gas connection (reference BS 6400-1 Section 6.2, Pressure absorption).

The external gas tap may reduce operating pressure further if measured at its test point. The pressure drop is relative to the heat input of the boiler (kW). Observe minimum gas pressure at the gas fitting in accordance with the table – see page 42

Operation with LPG

Purge the LPG tank twice on commissioning/replacement. Vent the tank and gas connection line thoroughly after purging.

1. Turn off the ON/OFF switch.
2. Close the gas shut-off valve.
3. Remove cover panel (A).
4. Undo screw (B) in the test connector on the gas solenoid valve, but do not remove it. Connect the pressure gauge.
5. Open the gas shut-off valve.
6. Measure the static pressure and record it in the report.
Set value: Max. 57.5 mbar (5.75 kPa).



Checking the static pressure and supply pressure (cont.)

7. Turn on the ON/OFF switch and start the boiler.

Note

During commissioning, the appliance can enter a fault state if there are airlocks in the gas line. Reset the appliance after approx. 5 s (see operating instructions).

8. Check the supply (flow) pressure. For set values, see the following table.

Note

Use a suitable measuring device with a resolution of at least 0.1 mbar (0.01 kPa) to check the supply pressure.

9. Record the value in the report. Implement measures as indicated in the table below.

10. Shut down the boiler. Close the gas shut-off valve. Remove the pressure gauge. Close test connector (B) with the screw.

11. Open the gas shut-off valve and start the appliance.



Danger

Gas escaping from the test connector leads to a risk of explosion. Check gas tightness at test connector (B).

12. Fit cover panel (A).

13. Fit front panel (see installation sequence).

Supply pressure (flow pressure)		Measures
For natural gas	For LPG	
< 13 mbar (1.3 kPa)	< 25 mbar (2.5 kPa)	Do not start the boiler. Notify the gas supply utility or LPG supplier.
13 - 25 mbar (1.3 - 2.5 kPa)	25 - 57.5 mbar (2.5 - 5.75 kPa)	Start the boiler.
> 25 mbar (2.5 kPa)	> 57.5 mbar (5.75 kPa)	Install a separate gas pressure governor upstream of the system. Set the pre-charge pressure to 20 mbar (2.0 kPa) for natural gas and 50 mbar (5.0 kPa) for LPG. Notify the gas supply utility or LPG supplier.



Function sequence and possible faults

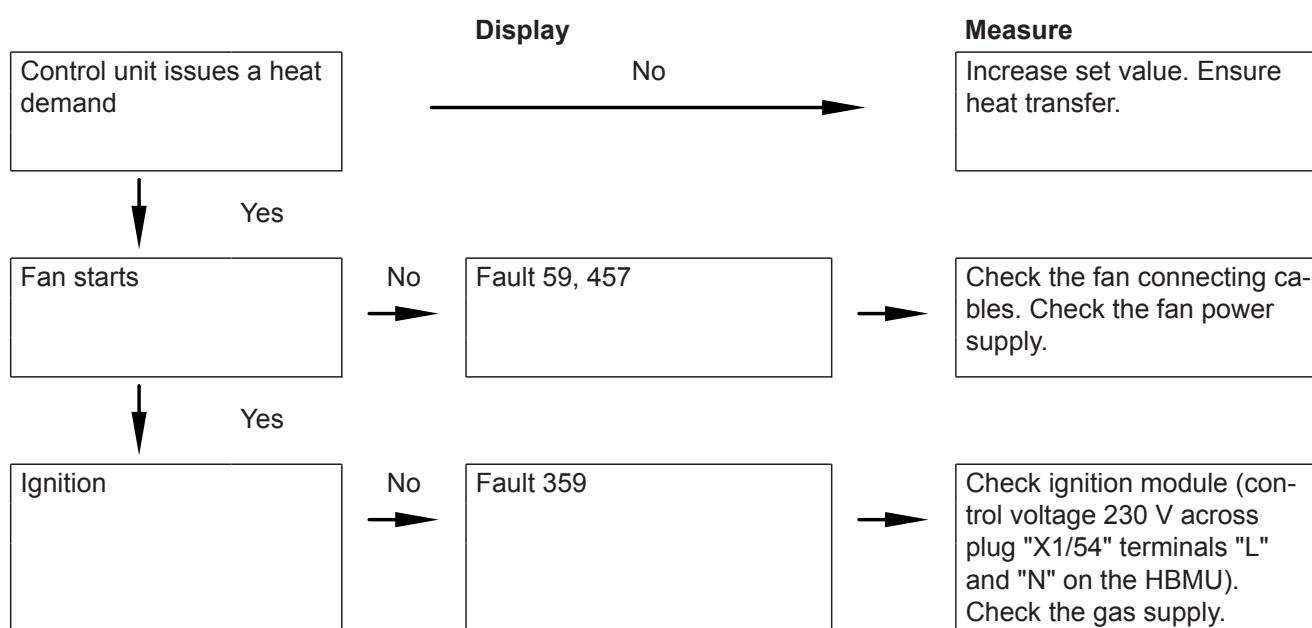



Function sequence and possible faults (cont.)

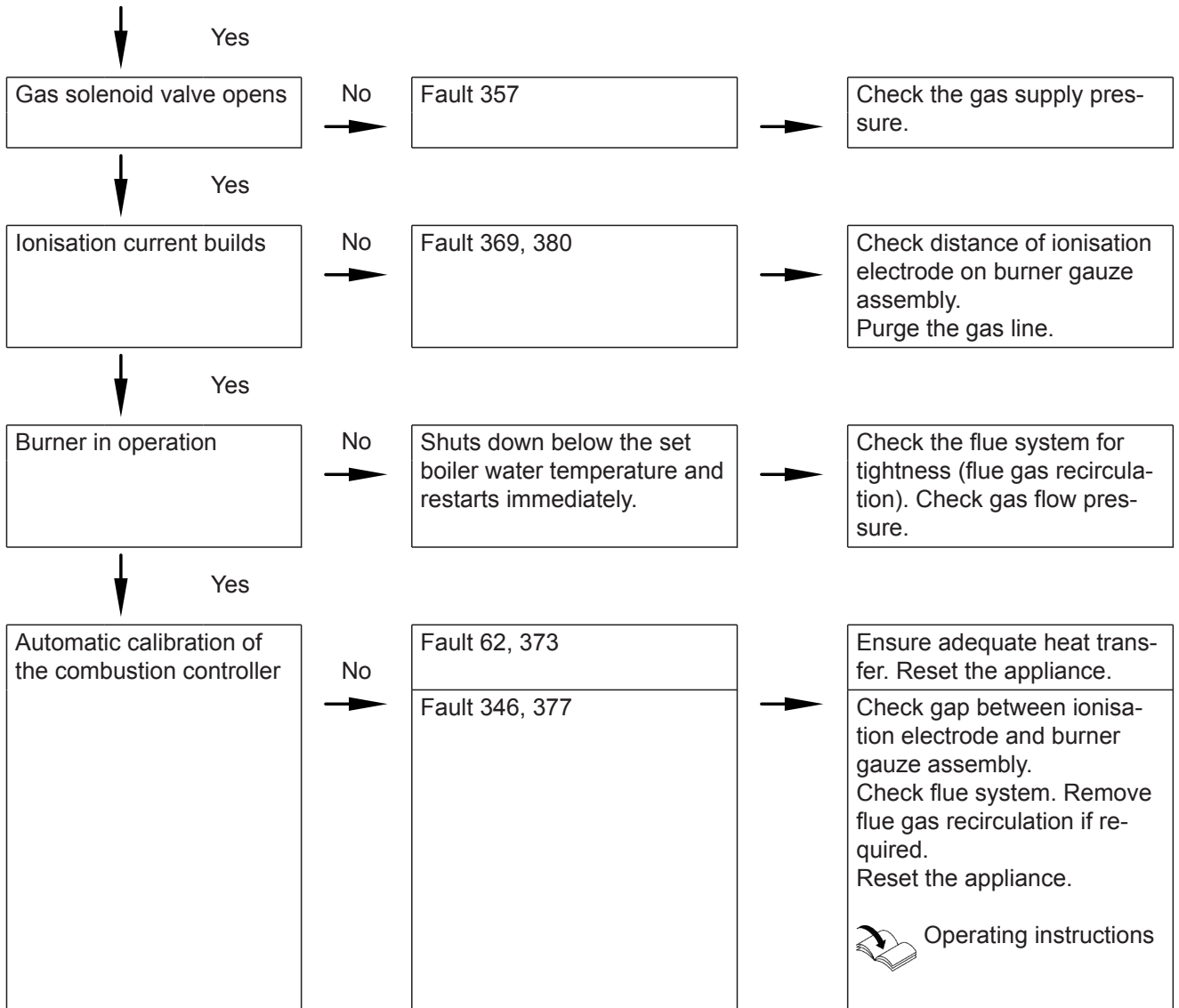

For further details regarding faults, see "Troubleshooting".



Setting the max. heating output

A limit can be set on the maximum heating output for **heating mode**. The limit is set via the modulation range.

Tap the following buttons:

- | | |
|---|---|
| <ol style="list-style-type: none"> 1. and OK simultaneously for approx. 4 s, then release. 2. Use to select "b.2" for system configuration. | <ol style="list-style-type: none"> 3. OK 4. Use to select "7" for max. heating output. 5. OK 6. Use to set the required value in % of rated heating output. Factory setting 100 %. 7. OK |
|---|---|



Performing an actuator test

The actuator test can only be set via the software tool.



Adjusting pump rate of integral circulation pump

Operation of the integral circulation pump as heating circuit pump for heating circuit 1

The pump speed and consequently the pump rate are controlled subject to the outside temperature and the switching times for heating mode or reduced mode. The minimum and maximum speeds for heating mode can be matched to the existing heating system at the control unit.

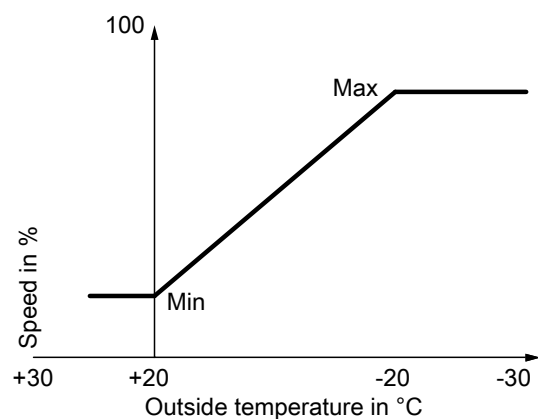

Fig. 25

- In the delivered condition, the minimum pump rate and the maximum pump rate are set to the following values:

Rated heating output in kW	Speed settings in the delivered condition in %	
	Min. pump rate	Max. pump rate
11	40	60
19	40	70
25	40	80
32	40	100

- In conjunction with a low loss header, heating water buffer cylinder and heating circuits with mixer, the internal circulation pump runs at a constant speed. Speed setting (%): Parameter 1100.2 in the Boiler group is possible via software tool.



Adjusting pump rate of integral circulation pump (cont.)

Residual head of integral circulation pump

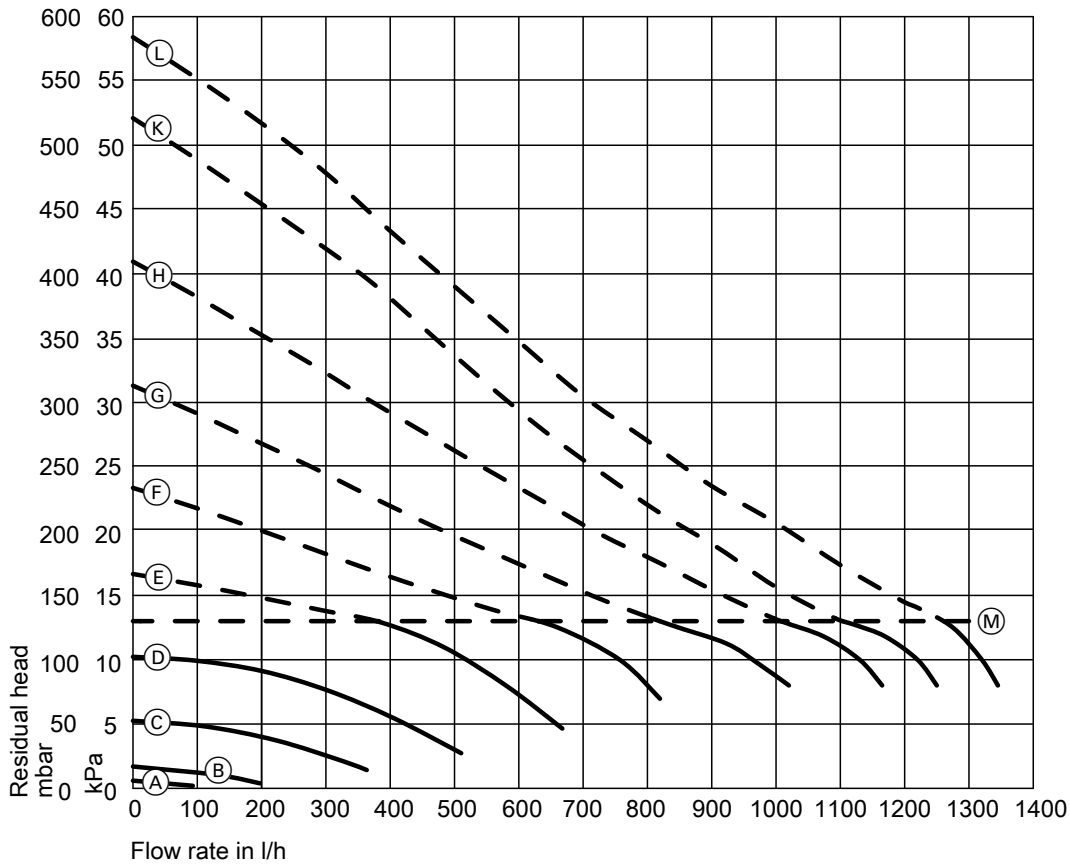

Fig. 26

(M) Upper operational limit

Curve	Pump rate of circulation pump
(A)	10 %
(B)	20 %
(C)	30 %
(D)	40 %
(E)	50 %
(F)	60 %
(G)	70 %
(H)	80 %
(K)	90 %
(L)	100 %



Activating screed drying

Screed drying

Six different temperature profiles can be set for screed drying:
 Default temperature profiles can be set in "**System configuration**".
 For further details, see "Function description".

Note

Screed drying applies to all connected heating circuits simultaneously. DHW heating is not possible during screed drying.



Leak test on balanced flue system (annular gap check)

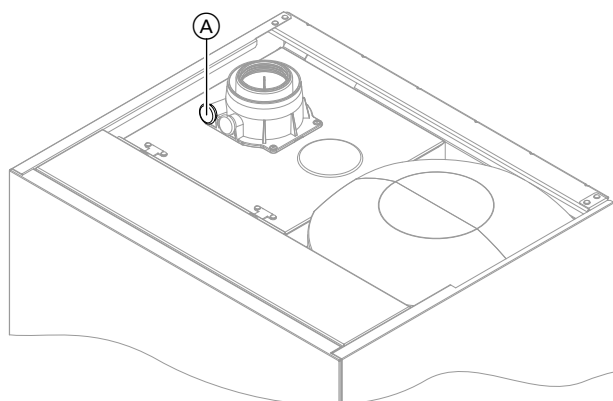

Fig. 27

Ⓐ Combustion air aperture

For balanced flue systems tested together with the heat generator, there is no requirement for a tightness test (overpressure test) during commissioning by the flue gas inspector.

In this case, we recommend that a simple tightness test is carried out during system commissioning. For this, check the CO₂ or O₂ concentration in the combustion air at the annular gap of the balanced flue pipe. If the CO₂ concentration is less than 0.2 % or the O₂ concentration is greater than 20.6 %, the flue pipe is deemed to be sufficiently gas-tight.

If actual CO₂ values are greater or O₂ values are lower, then pressure test the flue pipe with a static pressure of 200 Pa.



Please note

If the test port is not sealed, combustion air is drawn in from the room. After the tightness test, re-seal the test port with the plug.



Burner adjustment when connecting multiple flues to a shared flue system

Note

Only make this adjustment on appliances suitable for multiple connection.

For suitable Vitodens appliances, see pricelist.

When connecting several Vitodens 111-W to a common flue system:

For multiple connection, in the **commissioning assistant** use "C.4", "C.5" and "C.6" to match the burner setting to the flue system. See page 32

System conditions:

- Shared flue in shaft \varnothing 100 mm
- Balanced flue connection pipe from boiler to shaft, \varnothing 80/125 mm
- Minimum shaft cross-section
 - Square: 175 x 175 mm
 - Round: \varnothing 195 mm
- Height between floors min. 2.5 m
- Max. 6 boilers with the same rated heating output connected to the flue system



Removing the burner

Note

Remove cover panel, see page 41.



Removing the burner (cont.)

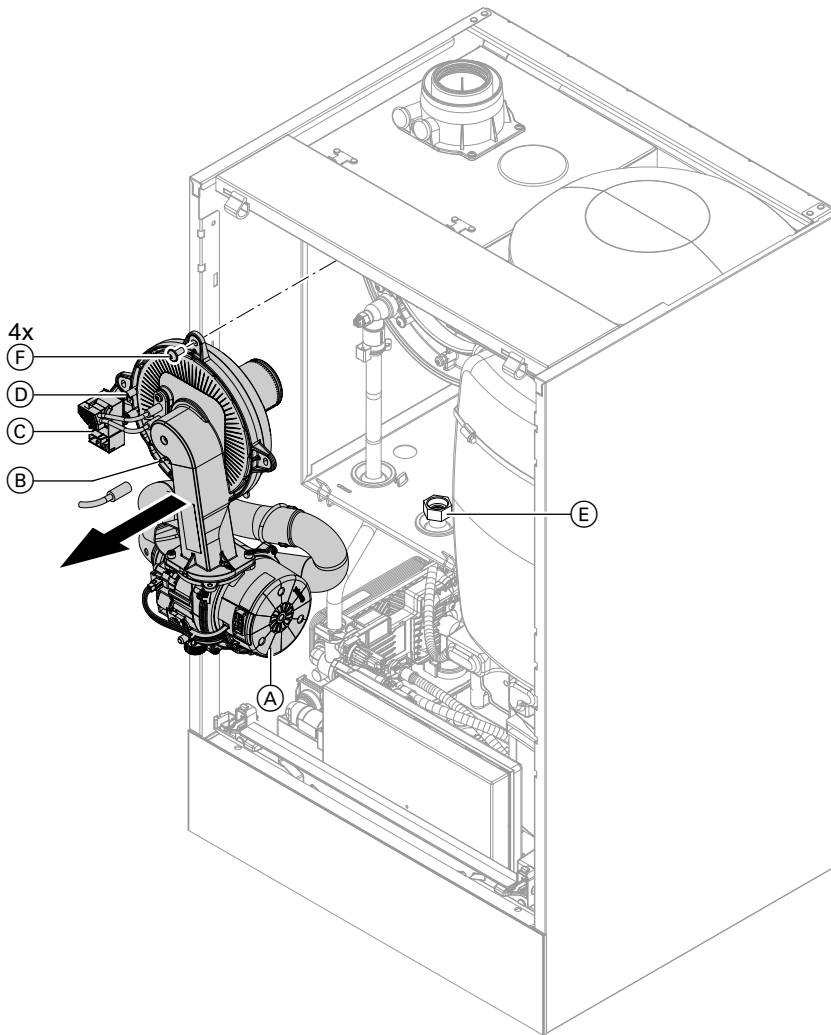

Fig. 28

1. Turn off the ON/OFF switch.
2. Close the gas shut-off valve and safeguard against reopening.
3. Disconnect cables and leads from:
 - Fan motor (A) (2 plugs)
 - Ionisation electrode (B)
 - Ignition unit (C)
 - Earth (D)
4. Undo gas supply pipe fitting (E).
5. Undo 4 screws (F) and remove the burner.

Note

Cover gas connection (E) so that no small parts can fall into it.



Checking the burner gasket and burner gauze assembly

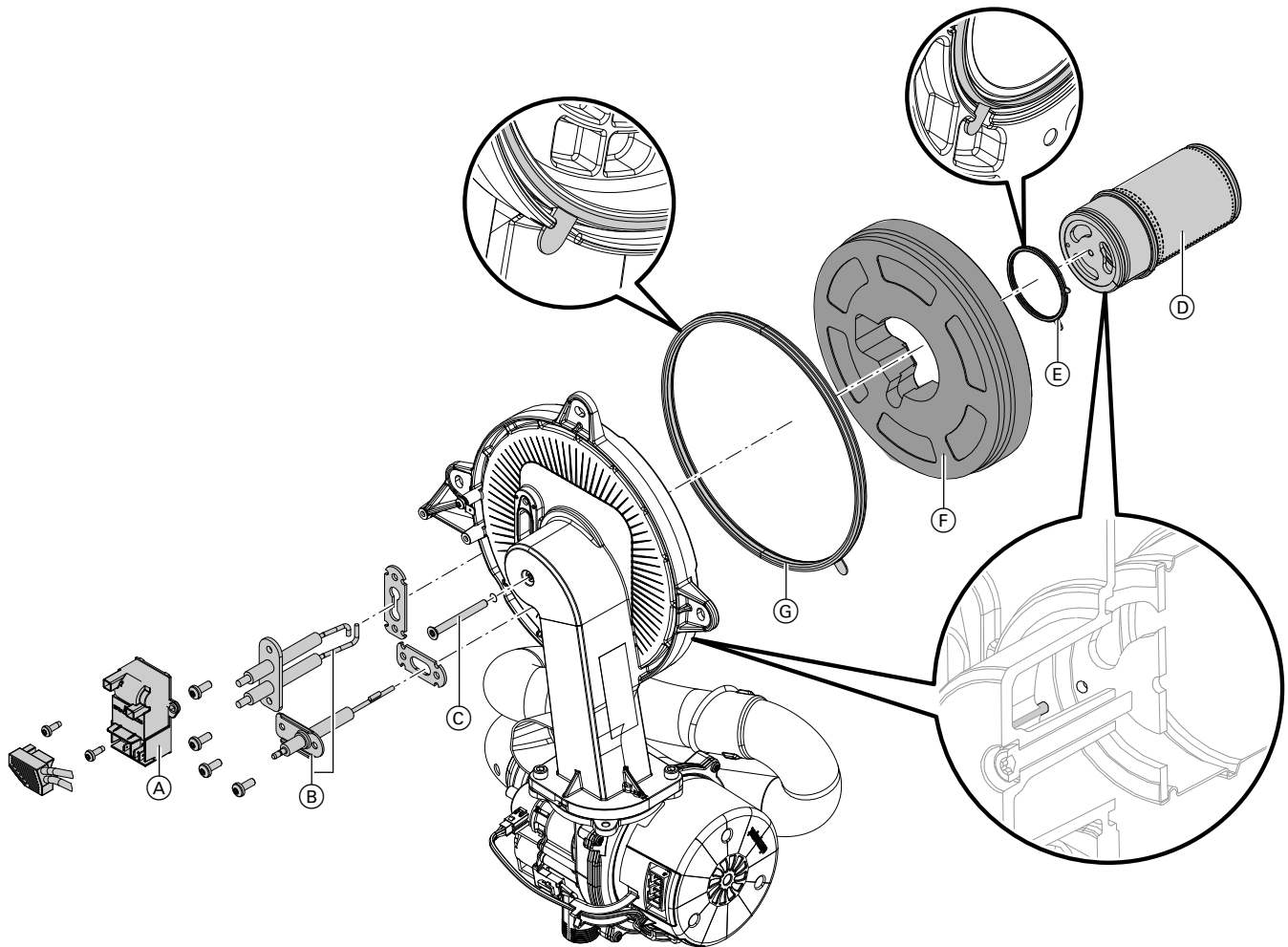

Fig. 29

Check burner gauze assembly (D), electrodes (B), thermal insulation ring (F) and gasket (G) for damage. Only remove and replace components if they are damaged or worn.

Note

If replacing the burner gauze assembly, also replace the gauze assembly gasket and the fixing screw.

1. Disconnect plug with ignition electrode leads from ignition unit (A).
2. Remove electrodes (B).
3. Undo Torx screw (C). Hold onto burner gauze assembly (D) when undoing the screw.
4. Remove burner gauze assembly (D) with gasket (E) and thermal insulation ring (F). Check components for damage.
5. Install new burner gasket (G). Observe correct installation position. Align the tab as per the diagram.
6. Insert thermal insulation ring (F) and burner gauze assembly (D) with gasket (E). Observe correct installation position. Align the tab as per the diagram.
7. Align the hole in burner gauze assembly (D) with the burner door pin. Secure burner gauze assembly (D) and gasket (E) with Torx screw (C). Tighten screws as tightly as necessary and ensure that the components are undamaged and are functioning correctly throughout service life. Observe torque settings if a torque wrench is available. Torque: 3.0 Nm.
8. Check thermal insulation ring (F) for firm seating.
9. Fit electrodes (B). Check clearances, see following chapter. Tighten screws as tightly as necessary and ensure that the components are undamaged and are functioning correctly throughout service life. Observe torque settings if a torque wrench is available. Torque: 4.5 Nm.



Checking and adjusting the ignition and ionisation electrodes

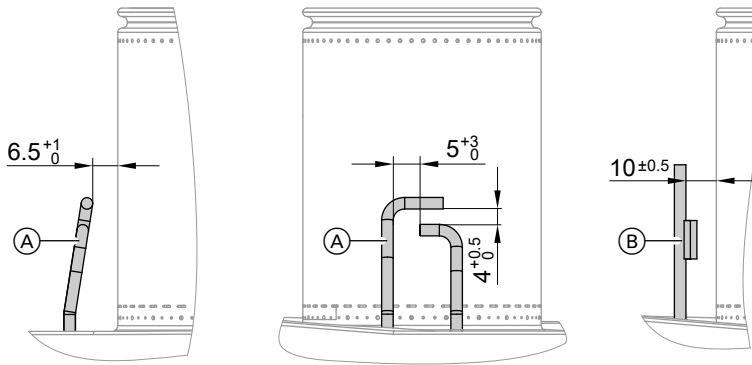

Fig. 30

- (A) Ignition electrodes
- (B) Ionisation electrode

1. Check the electrodes for wear and contamination.
2. Clean the electrodes with a small brush (not a wire brush) or sandpaper.
3. Check the electrode gaps. If the gaps are not as specified or the electrodes are damaged, replace the electrodes and gaskets and adjust them as required.
Tighten screws as tightly as necessary and ensure that the components are undamaged and are functioning correctly throughout service life.
Observe torque settings if a torque wrench is available.
Tighten the electrode fixing screws to a torque of 4.5 Nm.



Checking the back draught safety devices

Only for multiple connections to a flue system or multi boiler systems with a flue gas cascade.

Back draught safety device in the mixing shaft of the burner

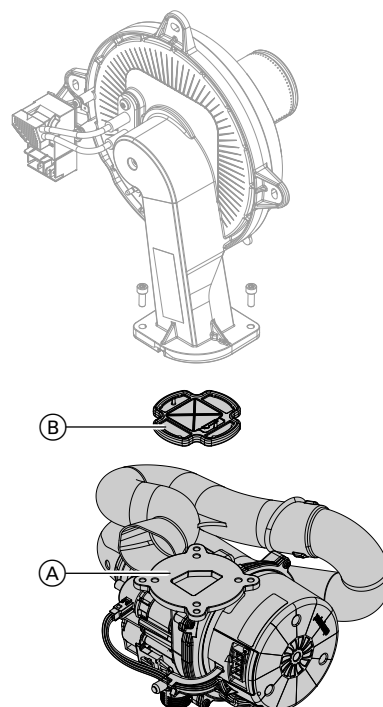

Fig. 31



Checking the back draught safety devices (cont.)

1. Undo 2 screws and remove fan (A).
2. Remove back draught safety device (B).
3. Check the damper and gasket for dirt and damage. Replace if necessary.
4. Refit back draught safety device (B).

Note

Observe correct installation position.

5. Refit fan (A) and secure with 2 screws. Tighten screws as tightly as necessary and ensure that the components are undamaged and are functioning correctly throughout service life. Observe torque settings if a torque wrench is available.
Torque: 4.0 Nm

1. Remove the balanced flue system.

Note

If the balanced flue system cannot be removed, clean and check the back draught safety device via the inspection cover.

2. Check back draught safety device (A) for dirt, ease of movement and function.
3. Refit the balanced flue system.
4. Pour a small amount of water through the inspection port to ensure the back draught safety device is working.

Back draught safety device in the flue gas connection

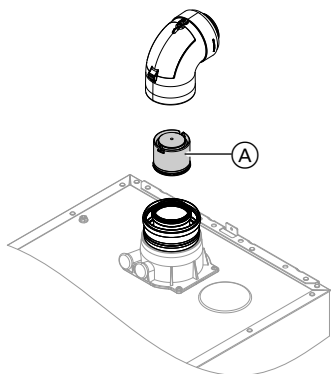

Fig. 32



Cleaning the heating surfaces



Please note

Scratches to the surfaces of the heat exchanger that come into contact with hot gas can result in corrosion damage. Brushing can cause deposits to become lodged in the gaps between the coils. **Never use brushes to clean the heating surfaces.**



Please note

Prevent damage due to cleaning water. Cover electronic components with suitable watertight material.

Note

Discolouration on the heat exchanger surface is a normal sign of use. It has no bearing on the function and service life of the heat exchanger. The use of chemical cleaning agents is not required.

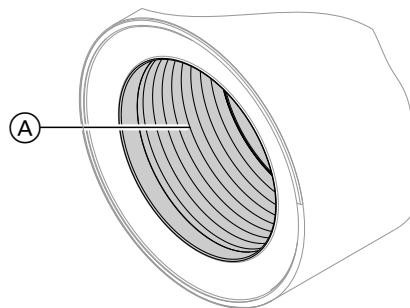

Fig. 33

1. Use a vacuum cleaner to remove combustion residues from heating surface (A) of the heat exchanger.
2. Flush heating surface (A) with water.



Cleaning the heating surfaces (cont.)

3. Check condensate drain. Clean the trap: See the following chapter.
4. Check the thermal insulation mat (if installed) in the heat exchanger for damage, replace if necessary.



Checking the condensate drain and cleaning the trap

! **Please note**
Prevent damage due to condensate.
Cover electronic components with suitable watertight material.

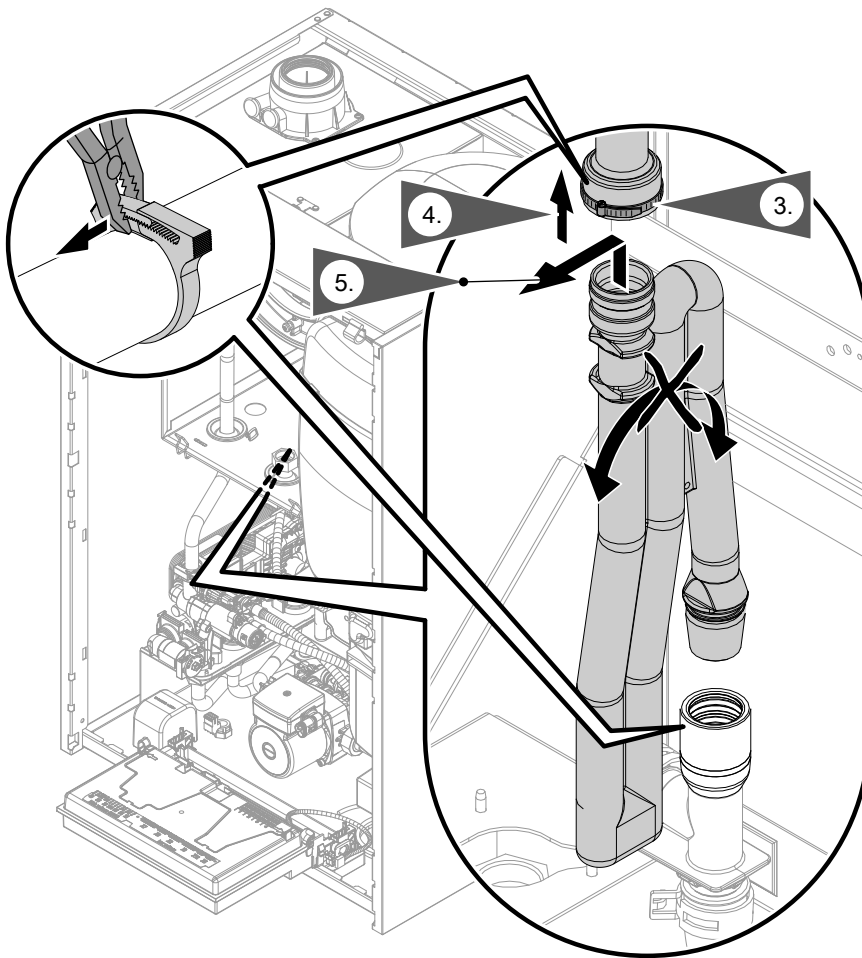

Fig. 34

1. Pivot the HBMU heat management unit forwards.
2. Undo the hose retainer. Remove the supply hose.
6. Fill the trap with water and reattach it to the drain connection.

! **Please note**
Do not undo using a sharp object. This can damage the condensate hose.
The hose retainer is detachable.

! **Please note**
If the trap is not filled with water, flue gas can escape.
Only start the appliance when the trap has been filled.

3. Pull trap upwards out of the drain connection.
4. Hold trap as straight as possible and remove. Ensure that no condensate runs out.
5. Clean the trap.
7. Reconnect the supply hose and secure in place with cable ties. Check that connections on the trap and the heat exchanger are seated correctly.





8.  **Danger**
 Risk of electric shock from escaping condensate and risk of poisoning from escaping flue gas.
 Check the connections for leaks and check that the trap is seated correctly.

Note

Route the drain hose without any bends and with a constant fall.

Multi boiler system:

Clean the trap in the flue gas collector as well.

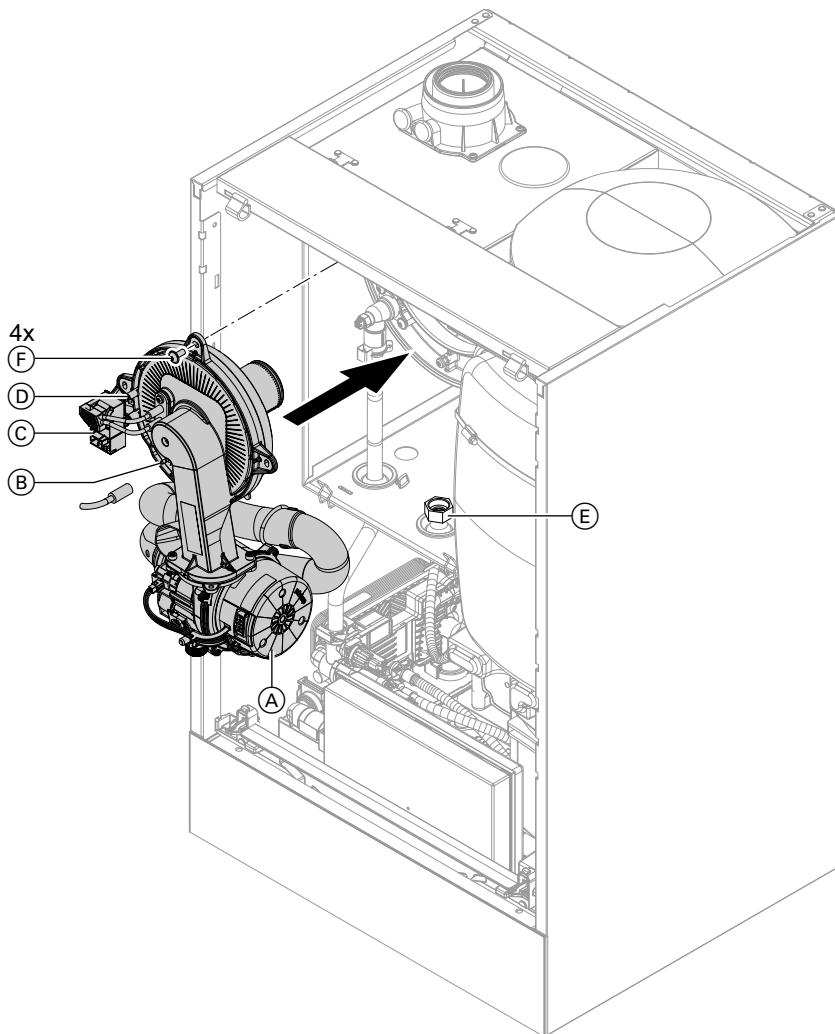

Fig. 35

1. Insert the burner. Tighten screws **F** diagonally. Tighten screws as tightly as necessary and ensure that the components are undamaged and are functioning correctly throughout service life. Observe torque settings if a torque wrench is available.
 Torque: 6.5 Nm



Installing the burner (cont.)

2. Fit gas supply pipe (E) with a new gasket. Tighten screws as tightly as necessary and ensure that the components are undamaged and are functioning correctly throughout service life. Observe torque settings if a torque wrench is available. Check for gas tightness to BSI 6891. Torque: 30 Nm
3. Check the gas connections for leaks.
4. Connect the cables/leads:
 - Fan motor (A) (2 plugs)
 - Ionisation electrode (B)
 - Ignition unit (C)
 - Earth (D)



Danger

Escaping gas leads to a risk of explosion. Check all fittings for gas tightness. In the case of wall mounted appliances, also check the gas shut-off valve fitting on the underside.



Checking the neutralising system (if installed)



Checking the expansion vessel and system pressure

Note

The expansion vessel can lose some of its charge pressure over time. When the boiler heats up, the pressure rises to 2 or 3 bar (0.2 or 0.3 MPa). The safety valve may also respond and discharge the excess pressure.

Therefore check the expansion vessel pre-charge pressure annually.

Check whether the installed expansion vessel is adequate for the system water volume. Carry out this test on a cold system.

1. Drain the system until "0" is shown on the display.
2. If the pre-charge pressure of the expansion vessel is lower than the static system pressure: Top up with nitrogen at the valve of the diaphragm expansion vessel until the pre-charge pressure is 0.1 to 0.2 bar (10 to 20 kPa) higher than the static system pressure.

3. Top up with water until the charge pressure of the cooled system is at least 1.0 bar (0.1 MPa), and is 0.1 to 0.2 bar (10 to 20 kPa) higher than the pre-charge pressure of the expansion vessel. Permiss. operating pressure: 3 bar (0.3 MPa)

Note

The expansion vessel is supplied from the factory with a pre-charge pressure of 0.7 bar. Do not allow the pre-charge pressure to fall below this value (boiling noises). This also applies to single floor heating systems or attic heating centres (no static pressure).

Top up with water until the charge pressure is 0.1 to 0.2 bar above the pre-charge pressure.



Checking the DHW expansion vessel (if installed) and the pre-charge pressure

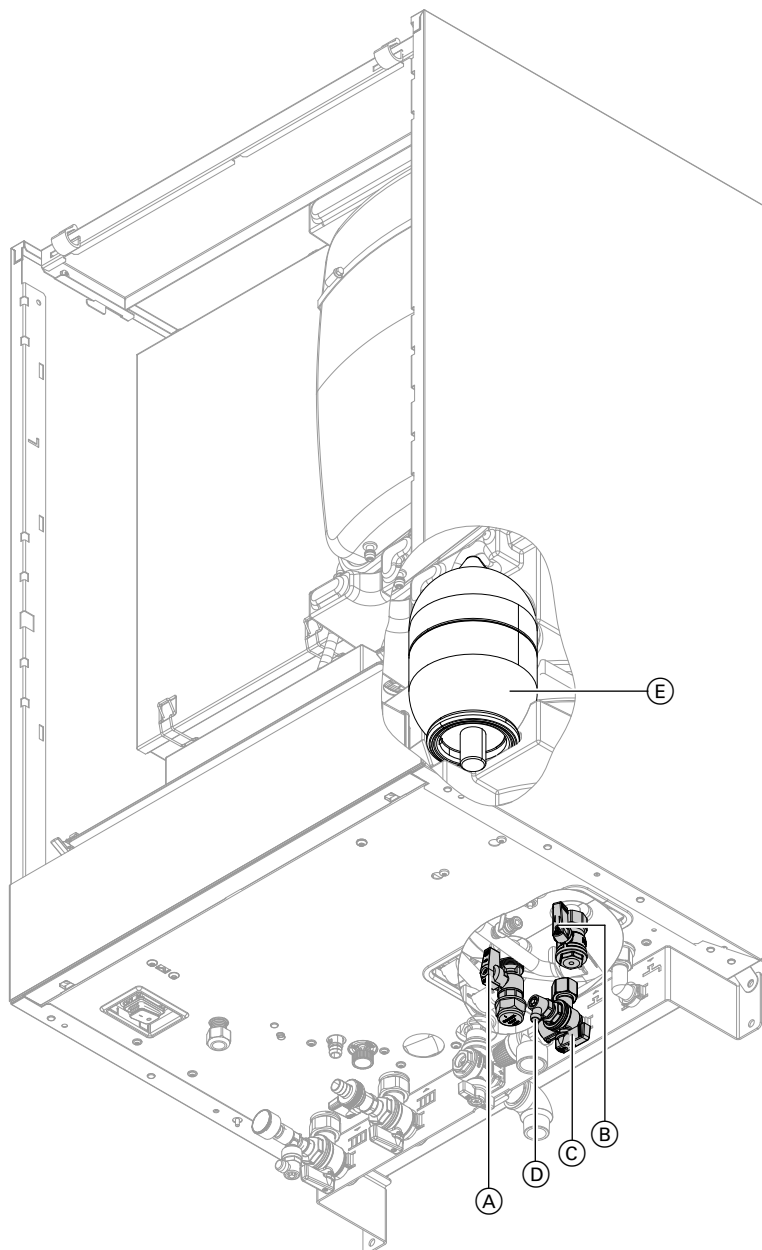

Fig. 36

1. Check the static pressure of the DHW line downstream of the pressure reducer and adjust if required. Set value: Max. 3.0 bar (0.3 MPa)
2. Close the on-site shut-off valve in the cold water line.
3. Turn levers on valves (A) and (B) to the "right-hand" position.
4. Close cold water supply (C).
5. Drain the pipe via air vent valve (D).
6. Check the pre-charge pressure of DHW expansion vessel (E) and adjust if necessary. Set value: Static pressure minus 0.2 bar (20 kPa)
7. Return the levers of valves (A) and (B) to the "top" position. Open cold water supply (C) and the on-site shut-off valve in the cold water line.



Checking the safety valve function



Checking the electrical connections for firm seating



Checking all gas equipment for leaks at operating pressure



Danger
Escaping gas leads to a risk of explosion.
Check gas equipment (including inside the appliance) for leaks.

Note
Only use suitable and approved leak detection agents (EN 14291) and devices for the tightness test. Leak detection agents with unsuitable constituents (e.g. nitrides, sulphides) can cause material damage. Remove residues of the leak detection agent after testing.



Fitting the front panel

See page 30.



Checking the combustion quality

The electronic combustion controller automatically ensures optimum combustion quality. During commissioning/maintenance, only the combustion values need to be checked. To do this, test the CO content and CO₂ or O₂ content, and record these in the report on page 101.

Note
To prevent operating faults and damage, operate the appliance with uncontaminated combustion air.

Permissible CO content

The CO content must be < 1000 ppm for all gas types.

Permissible CO₂ or O₂ content

Operation with natural gas

Rated heating output (kW)	CO ₂ content (%)		O ₂ content (%)	
	Upper heating output	Lower heating output	Upper heating output	Lower heating output
25	7.5 - 10.5	7.5 - 10.5	2.1 - 7.6	2.1 - 7.6
32	7.3 - 10.0	7.3 - 10.5	3.1 - 7.9	2.1 - 7.9

Operation with LPG

- CO₂ content: 8.4 - 11.8 %
- O₂ content: 3.1 - 8.1 %

If the actual CO, CO₂ or O₂ values lie outside their respective ranges, proceed as follows:

- Check the balanced flue system for leaks; see page 46.
- Check the ionisation electrode and connecting cable, see page 49.

Note

During commissioning, the combustion controller carries out an automatic calibration. Allow approx. 50 s after the burner has started before testing the emissions.

   **Checking the combustion quality** (cont.)

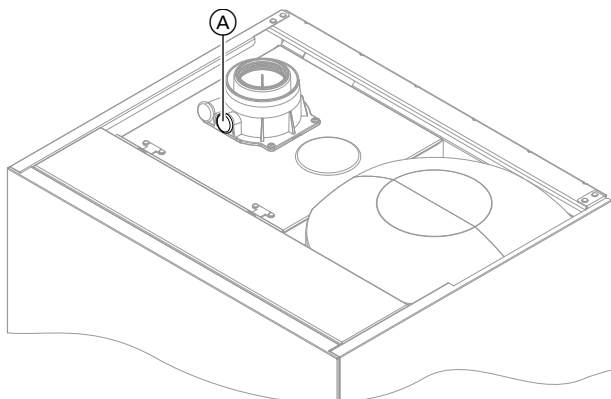

Fig. 37

1. Connect a flue gas analyser at flue gas port (A) on the boiler flue connection.
2. Open the gas shut-off valve. Start the boiler. Create a heat demand.
3. Adjust the lower heating output. See the following chapter.
4. Check the CO₂ content. If the actual value deviates from the permissible ranges, implement steps listed above.
5. Enter the actual value into the report.
6. Adjust the upper heating output. See the following chapter.
7. Check the CO₂ content. If the actual value deviates from the permissible ranges by more than 1 %, implement steps listed above.
8. Enter the actual value into the report.
9. Re-seal test port (A).



Danger



Escaping flue gas can damage your health. Check test port (A) for leaks.

Regulating to the upper/lower heating output

Note

Ensure adequate heat transfer.

Tap the following buttons:

1.  and **OK** simultaneously for approx. 4 s, then release.
2. Use  to select "b.6" for the upper/lower heating output.
3. **OK**
4. Use  to set the value.
 "0" - OFF
 "1" - Min. heating output
 "2" - Max. heating output
5. **OK**
 Burner is operating with correspondingly adjusted heating output.

   **Checking the flue system for unrestricted flow and leaks**

   **Checking the external LPG safety valve (if installed)**

   **Matching the control unit to the heating system**

The control unit must be matched to the system equipment level.

Set the parameters according to the accessories fitted:



Matching the control unit to the heating system (cont.)



Accessories installation and service instructions



Adjusting the heating curves

Tap the following buttons:

- 1.
2. Use to select "P.3" for heating curve.
3. **OK**
4. Use to select "HC1" for "heating circuit 1" or "HC2" for "heating circuit 2".
5. **OK**
6. Use to set the slope.
7. **OK**
8. Use to set the level.
9. **OK** to confirm



Instructing the system user

The system installer should hand the operating instructions to the system user and instruct the user in operating the system.

This includes all components installed as accessories, e.g. remote control units. In addition, the system installer must make the user aware of the required maintenance work.

DHW hygiene

For optimum DHW hygiene, avoid DHW temperatures that are < 50 °C. For larger systems and systems with low water exchange, the temperature should not drop below < 60 °C.

Inform the system user what DHW temperatures should be set and the risks associated with having a raised outlet temperature at the draw-off points.

System configuration (parameters)



Calling up parameters



Note

The display and setting of some parameters is dependent on:

- Heat generator
- Connected accessories and the functions associated with them

Tap the following buttons:

1.  and **OK** simultaneously for approx. 4 s, then release.
2. Use  to select "b.2" for system configuration.

3. **OK**
4. Use  to select the parameter for adjustment. See tables below.
5. **OK**
6.  for the required value.
7. **OK**

Parameter

Note

Parameter values in **bold** are factory settings.

1 "Set flow temperature for external demand"

Setting	Explanations
70 20 to 82	Set flow temperature for external demand Set flow temperature in the delivered condition 70 °C Set flow temperature adjustable from 20 to 82 °C in 1 °C increments

2 "Primary circuit pump operating mode"

Setting	Explanations
1	"Automatic" Switched on regardless of current temperature level
7	Switched off in reduced mode (in conjunction with constant operation with time program) or if there is no demand via the room thermostat.

Parameter (cont.)**3 "Scald protection"**

Setting		Explanations
Out	0	The adjustable DHW temperature is limited to a maximum value. Scald protection OFF  Danger Risk of injury due to increased DHW temperature. Inform the system user of the risk from the raised outlet temperature at the draw-off points.
In	1	Scald protection ON (maximum DHW temp. 60 °C) Note <i>Even with the scald protection switched on, higher outlet temperatures may occur at the draw-off points in the following cases:</i> ▪ <i>While the appliance is being calibrated</i>

4 "Max. speed of speed-controlled primary/heating circuit pump in standard mode, heating circuit 1"

Setting		Explanations
	...	Maximum speed of the internal circulation pump in heating mode with standard room temperature Delivered condition specified by settings specific to the heat generator
	0 to 100	Maximum speed adjustable from 0 to 100 %

5 "Screed drying"

Setting		Explanations
Not active	0	Screed drying can be set in accordance with selectable temperature/time profiles. For individual profile curves, see chapter "Function description".
Temperature profile A	2	
Temperature profile B	3	
Temperature profile C	4	
Temperature profile D	5	
Temperature profile E	6	
Temperature profile F	7	

6 "Minimum heating output"

Setting		Explanations
	...	A limit can be set on the minimum heating output for heating mode. Delivered condition specified by settings specific to the appliance
	0 to 100	Adjustable from 0 to 100 %

System configuration (parameters)

Parameter (cont.)

7 "Maximum heating output"

Setting		Explanations
	100 0 to 100	A limit can be set on the maximum heating output for heating mode. Heating output in the delivered condition 100 % Adjustable from 0 to 100 %

8 "Maximum flow temperature limit, heating circuit 1"

Setting		Explanations
74 °C	74 10 to 100	Maximum flow temperature limit for the heating circuit Maximum limit in the delivered condition 74 °C Setting range limited by heat generator-specific parameters

9 "Operating mode, heating circuit 1"

Setting		Explanations
	4 7	Only adjust if there is just a single heating circuit in the system. Weather-compensated without room temperature influence Weather-compensated with room temperature influence; see also parameter 10.

10 "Room influence factor, heating circuit 1"

Setting		Explanations
8	8 0 to 64	The higher the value, the greater the influence of the room temperature on the set flow temperature of the heating circuit (heating curve). Operation with room temperature hook-up must be set for the heating circuit. Only change the value for systems with one heating circuit. For a sample calculation, see chapter "Heating curve" under "Function description" Maximum limit in the delivered condition Setting range

11 "Maximum flow temperature limit, heating circuit 2"

Setting		Explanations
74 °C	74 10 to 100	Maximum flow temperature limit for the heating circuit Maximum limit in the delivered condition 74 °C Setting range limited by heat generator-specific parameters

12 "Operating mode of heating circuit 2"

Setting		Explanations
Weather-compensated without room temperature hook-up	4	Heating mode: Weather-compensated without room temperature influence
Weather-compensated with room temperature hook-up	7	Weather-compensated with room temperature influence See parameter 13.

Parameter (cont.)**13 "Room influence factor, heating circuit 2"**

Setting		Explanations
8	8 0 to 64	The higher the value, the greater the influence of the room temperature on the set flow temperature of the heating circuit (heating curve). Operation with room temperature hook-up must be set for the heating circuit. Change value for heating circuit with mixer only. For a sample calculation, see chapter "Heating curve" under "Function description" Maximum limit in the delivered condition Setting range

Additional settings can be made only via software tool**1667.0 Pump control, heating circuit pump 1 in standby mode**

Setting		Explanations
	0 1-24	Operating mode, heating circuit pump 1 (only when in constant operation) In "standby mode" = permanently switched off In "standby mode", = started 1 to 24 times per day for 10 min each time

1668.0 Pump control, heating circuit pump 2 in standby mode

Setting		Explanations
	0 1-24	Operating mode, heating circuit pump 2 (only when in constant operation) In "standby mode" = permanently switched off In "standby mode", = started 1 to 24 times per day for 10 min each time

2426.1 Weather-compensated heating circuit pump logic function (only for weather-compensated control units).

Setting		Explanations
		If the outside temperature is above the threshold value (selected set room temperature plus hysteresis in K), the heating circuit pump is switched off. If the outside temperature is below the threshold value (selected set room temperature plus hysteresis in K), the heating circuit pump is switched on.

Parameter (cont.)

2426.2 Room temperature-dependent heating circuit pump logic (only for weather-compensated control units with room temperature hook-up).

Setting	Explanations
Only activate this function for the heating circuit with mixer or if there is only one direct heating circuit in the system.	If the actual room temperature is above the threshold value (selected set room temperature plus hysteresis in K), the heating circuit pump is switched off. If the actual room temperature is below the threshold value (selected set room temperature plus hysteresis in K), the heating circuit pump is switched on.

Subscriber numbers of connected extensions

All extensions connected to the heat generator (except the SDIO/SM1A electronics module) must have a subscriber number. The subscriber number is set on rotary switch S1 at each extension.

Observe maximum number of PlusBus subscribers, see note in chapter "Connection".

Rotary switch S1 settings:

- EM-S1 extension (system with solar collectors): **0**
- EM-EA1 extension (max. 1 extensions in one system)

Note

On the EM-EA1 extension, select 1 if the "External heating circuit hook-up" function is being set for more than one heating circuit.

- EM-P1 extension
 - If no heating circuits with mixer are available in the system: **1**
 - If heating circuits with mixer (EM-M1 or EM-MX extensions) are present in the system: Always set subscriber number for EM-P1 extension to the consecutive number after EM-M1 or EM-MX extensions.
- EM-M1 or EM-MX extensions
 - Heating circuit 2 with mixer: Rotary switch on extension kit to 1

Note

*EM-EA1 extensions may have the same subscriber number as the EM-P1, EM-M1 or EM-MX extensions. The following table shows an **example** of how a system may be equipped.*

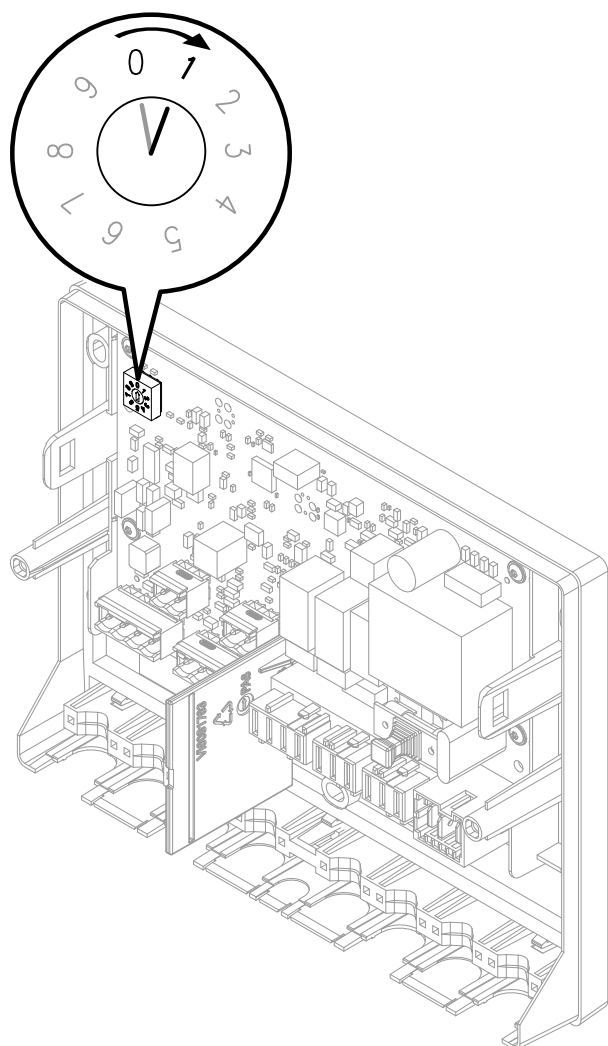

Fig. 38

Subscriber numbers of connected extensions (cont.)

Function	Electronics module	Extension	Setting Rotary switch S1
System with solar collectors	ADIO	EM-S1	0
Heating circuit 2 with mixer	ADIO	EM-M1/EM-MX	1
Heating circuit 1 without mixer or DHW circulation pump (circulation pump downstream of low loss header)	ADIO	EM-P1	2
Function extensions (e.g.): <ul style="list-style-type: none"> ▪ Fault message input ▪ Fault message output ▪ Operating mode changeover ▪ External heating circuit hook-up (for more than one heating circuit) 	DIO	EM-EA1	1

Note

A maximum of one Vitotrol 200-E can be connected

Service menu

Calling up the service menu

Tap the following buttons:

1.  and **OK** simultaneously for approx. 4 s, then release.
2. Select the required menu section (e.g. **"b.1"** Connect with software tool).

Note

Tap  to return to the service menu.

Note

Not all menu areas will be available, depending on the system equipment level.

Service menu overview

Service	
Er Active messages	
b.1 Connect with software tool	
b.2 System configuration	
b.3 Diagnostics	
	d.1 Outside temperature
	d.2 Heat generator flow temperature
	d.3 Primary circuit pump speed %
	d.4 Flue gas temperature
	d.5 Burner hours run
	d.6 Burner output
	d.7 3-way valve position
	0 = Heating
	1 = Middle position (if installed)
	2 = DHW
	d.8 Serial number of heat generator
	d.9 Heating circuit 1 flow temperature
	d.10 Heating circuit 2 flow temperature
	d.11 DHW temperature
b.4 Message history	
b.5 Commissioning assistant	
b.6 Start upper/lower heating output for trade fair mode	

Diagnosis

Exiting the service menu

Tap the following buttons:

 and **"OK"** simultaneously for 4 s.

Note

The system exits the service menu automatically after 30 min.

Diagnosis

Checking operating data

Operating data can be checked in various areas. See "**Diagnosis**" in the service menu overview.

Operating data on heating circuits with mixer can only be called up if such components are installed in the system.

Note

If a called-up sensor has a lead break or short circuit, "- - -" appears on the display.

Calling up operating data

Tap the following buttons:



1.  and **OK** simultaneously for approx. 4 s, then release.

2. Use / to select "**b.3**" for diagnostics.

3. **OK**

4. Use / to select the required entry.

Note

"d.8" Use / to view the heat generator serial number in sections.

5. **OK**

Fault display on the programming unit



A fault in the burner control unit causes the display to show "△".

Note

If a central fault message facility is connected, this is switched on.

Calling up fault messages

Tap the following buttons:

1.  and **OK** simultaneously for approx. 4 s, then release.
2.  for "Er" message list
3. **OK**
4.  to select fault entry "E.1, E.2...".
5. **OK**
6. Fault code is displayed.



Acknowledging the fault display

Calling up the fault in the "Er" menu automatically acknowledges the fault display.

Calling up acknowledged fault messages

Tap the following buttons:





1. 
2.  to select "Er".

3. **OK**
4.  to call up fault entry "E.1 to E.5".
5. **OK**
6.  display fault code.

Calling up fault messages from the fault memory (message history)

The 5 most recent faults (including those remedied) are saved and can be called up. Faults are sorted by date.

Tap the following buttons:

1.  and **OK** simultaneously for approx. 4 s, then release.
2.  for "b.4" message history
3. **OK**
4. Use  to select fault entry "E.1, E.2... or E.5".
For messages, see chapter "Fault messages".
5. **OK**
6.  for the required message
7. **OK**

Overview of electronics modules

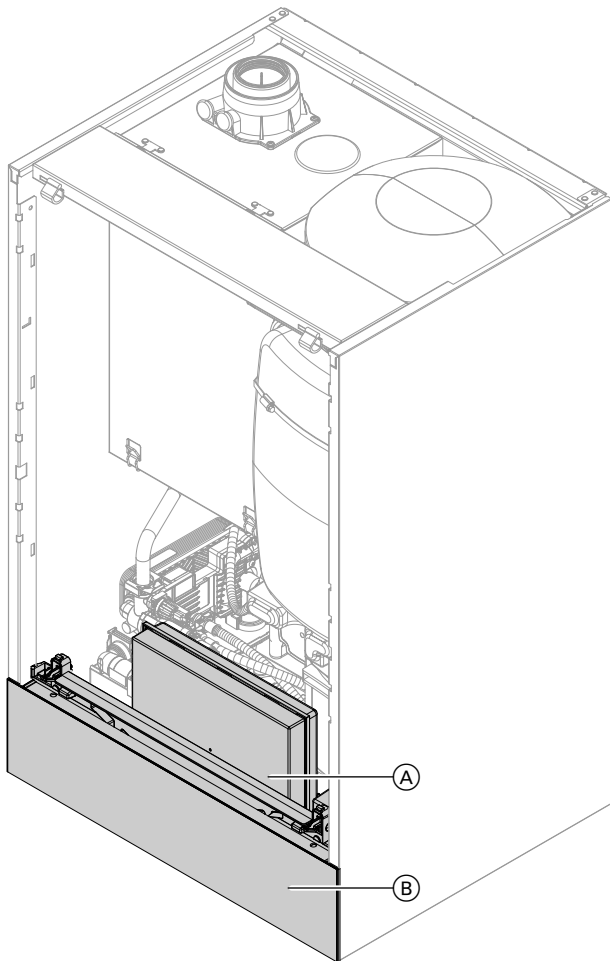

Fig. 39

- (A) HBMU heat management unit
- (B) Programming unit

Fault messages

Note

For diagnosis and troubleshooting, see chapter "Repairs".

Fault messages dependent on appliance equipment level

Fault messages (cont.)

Displayed fault code	System characteristics	Cause	Measures
7	No DHW heating.	Lead break, cylinder temperature sensor	<ul style="list-style-type: none"> ▪ Check DHW setting in the commissioning assistant and correct if required. ▪ Check the cylinder temperature sensor (terminal 2). ▪ Measure voltage at sensor input on HBMU heat management unit. Set value: 3.3 V– with sensor disconnected. Replace faulty component if required.
8	No DHW heating	Short circuit, cylinder temperature sensor	Check the cylinder temperature sensor (terminal 2). Replace faulty component if required.
11	No solar DHW heating or central heating backup	Lead break, collector temperature sensor	<ul style="list-style-type: none"> ▪ Check collector temperature sensor. ▪ Measure voltage at sensor input on electronics module (ADIO). Set value: 3.3 V– with sensor disconnected
12	No solar DHW heating	Short circuit, collector temperature sensor	<ul style="list-style-type: none"> ▪ Check collector temperature sensor. ▪ Measure voltage at sensor input on electronics module (ADIO). Set value: 3.3 V– with sensor disconnected
13	Controls as if the outside temperature were 0 °C	Lead break, outside temperature sensor	<ul style="list-style-type: none"> ▪ Check operating mode setting in commissioning assistant and remedy if required. ▪ Check outside temperature sensor and connection to sensor (terminal 4). ▪ Measure voltage at sensor input on HBMU heat management unit. Set value: 3.3 V– with sensor disconnected. Replace faulty component if required.
14	Controls as if the outside temperature were 0 °C	Short circuit, outside temperature sensor	Check outside temperature sensor and connection to sensor (terminal 4). Replace faulty components if necessary.
15	No solar DHW heating	Lead break, solar cylinder temperature sensor (bottom)	Check cylinder temperature sensor. Measure voltage at sensor input on ADIO electronics module. Set value: 3.3 V– with sensor disconnected
16	No solar DHW heating	Short circuit, solar cylinder temperature sensor (bottom)	Check cylinder temperature sensor. Measure voltage at sensor input on ADIO electronics module. Set value: 3.3 V– with sensor disconnected

Fault messages (cont.)

Displayed fault code	System characteristics	Cause	Measures
29	Regulates without flow temperature sensor for low loss header.	Lead break, low loss header sensor	<ul style="list-style-type: none"> ▪ Check commissioning assistant setting, low loss header. ▪ Check flow temperature sensor, low loss header. ▪ Measure voltage at sensor input on electronics module. Set value: 3.3 V– with sensor disconnected
30	Regulates without flow temperature sensor for low loss header.	Short circuit, low loss header sensor	Check flow temperature sensor, low loss header. Measure voltage at sensor input on electronics module. Set value: 3.3 V– with sensor disconnected
49	Burner in a fault state	Lead break, flue gas temperature sensor	Check flue gas temperature sensor. Reset the appliance.
50	Burner in a fault state	Short circuit, flue gas temperature sensor	Check flue gas temperature sensor. Reset the appliance.
57	Control mode without room influence	Lead break, room temperature sensor	<ul style="list-style-type: none"> ▪ Check commissioning setting of remote control. ▪ Check plug and cable of external room temperature sensor, heating circuit. ▪ If no external room temperature sensor installed, replace Vitotrol programming unit.
58	Control mode without room influence	Short circuit, room temperature sensor	Check plug and cable of external room temperature sensor, heating circuit. If no external room temperature sensor installed, replace Vitotrol programming unit.
59	Burner blocked, boiler circuit pump off. No central heating, no DHW heating	Power supply, low voltage	Check mains voltage. If voltage is correct and the fault occurs repeatedly, replace the fan unit.
62	Burner in a fault state	High limit safety cut-out has responded.	<ul style="list-style-type: none"> ▪ Check heating system fill level. ▪ Check pre-charge pressure in diaphragm expansion vessel. Adjust to required system pressure. ▪ Check whether flow rate is sufficient (circulation pump). ▪ Check function of 3-way diverter valve. Vent the system. Reset the appliance.



Fault messages (cont.)

Displayed fault code	System characteristics	Cause	Measures
63	Burner in a fault state	Flue gas temperature limiter has responded.	<ul style="list-style-type: none"> ▪ Check heating system fill level. ▪ Check pre-charge pressure in diaphragm expansion vessel. Adjust to required system pressure. ▪ Check whether flow rate is sufficient (circulation pump). ▪ Check function of 3-way diverter valve. Vent the system. Reset the appliance once the flue system has cooled down.
67	Burner in a fault state	Ionisation current lies outside the permissible range	Check gas supply (gas pressure and gas flow switch), check gas solenoid valve and inlet strainer. Check ionisation electrode for the following: <ul style="list-style-type: none"> ▪ Clearance to burner gauze assembly ▪ Check electrode/burner gauze assembly for contamination. If specified measures don't help, replace fan unit. Reset the appliance.
68	Burner in a fault state	Flame signal is already present at burner start.	Close the gas shut-off valve. Remove connecting cable of the ionisation electrode. Reset the appliance. If the fault persists, replace the HBMU heat management unit. See chapter "Replacing the HBMU heat management unit".
69	Burner in a fault state	Ionisation current lies outside the permissible range	Check ionisation electrode for the following: <ul style="list-style-type: none"> ▪ Check whether insulation block is touching electrode ceramic. ▪ To check the gas solenoid valve: In the service menu under "b.6", set the burner output to the lower heating output for approx. 4 min. If the fault occurs, replace the HBMU heat management unit. See chapter "Replacing the HBMU heat management unit". ▪ In the service menu under "b.6", switch the burner output from the lower to the upper heating output. If this fault occurs during modulation, check the intake screen for contamination. Replace the fan unit if necessary.
70	Burner in a fault state	HBMU heat management unit internal fault	Replace the HBMU heat management unit. See chapter "Replacing the HBMU heat management unit".

Fault messages (cont.)

Displayed fault code	System characteristics	Cause	Measures
71	Burner in a fault state	Fan speed too low	<ul style="list-style-type: none"> ▪ Check fan for blockage. ▪ Check setting for gas type and flue system. Reset the appliance.
73	Burner in a fault state	Internal communication error	Reset the appliance. If the fault occurs repeatedly, replace the HBMU heat management unit. See chapter "Replacing the HBMU heat management unit".
74	Burner locked out. Internal circulation pump off. No central heating and no DHW heating.	System pressure too low	Top up with water. Vent the system. If the fault occurs repeatedly: <ul style="list-style-type: none"> ▪ Check system pressure sensor with external pressure gauge. ▪ Check diaphragm expansion vessel pre-charge pressure. ▪ Check settings for set system pressure and range.
77	Burner in a fault state	HBMU heat management unit data memory	Reset the appliance. If the fault occurs repeatedly, replace the HBMU heat management unit. See chapter "Replacing the HBMU heat management unit".
89	No central heating and no DHW heating	Internal circulation pump blocked	Check circulation pump. Replace if necessary.
91	Function of affected extension in emergency mode	DIO electronics module communication error	Check connections to DIO electronics module and connection to HBMU heat management unit.
92	Function of the relevant electronics module in emergency mode	ADIO electronics module communication error	<ul style="list-style-type: none"> ▪ Check setting in the commissioning assistant and correct if required. ▪ Check connections and leads to the ADIO electronics module. ▪ Check PlusBus voltage level (24 to 28 V). ▪ Check subscriber number on rotary switch S1 and correct if required.
95	Burner off	OpenTherm remote control unit not connected	<ul style="list-style-type: none"> ▪ Check connection to the OpenTherm remote control. unit. ▪ If OpenTherm is not required, set C.7 in the commissioning assistant to a value other than 14.
100	Electronics modules connected to PlusBus not functioning	Voltage error PlusBus	Check whether the PlusBus power supply on the HBMU heat management unit is OK: Remove all connected PlusBus components and reconnect one by one. Check that no more than 1 Vitotrol 200-E is connected to the HBMU. Check whether there is a short circuit at the PlusBus cable.



Fault messages (cont.)

Displayed fault code	System characteristics	Cause	Measures
102	No internet connection	Error with communication module	Check cables and plug-in connections between heat management unit and communication module.
103	Control mode	Internal communication error, programming unit	Check cables and plug-in connections between heat management unit and HMI programming unit.
104	Depending on configuration of EM-EA1 extension (DIO electronics module)	External fault message input active	Check connected external device.
142	Burner in a fault state	Communication restriction on CAN bus. INR	Check the fan unit for correct function. For this, check the stepper motor of the fan unit (reference run with mains ON). If the fault persists, check the plug-in connections and cables of the CAN bus. Check further CAN bus subscribers. If fault occurs repeatedly, replace fan unit.
160	Burner in a fault state	Communication error, CAN bus	Check connection to CAN bus subscribers (INR, HBMU). Check connections to external CAN bus subscribers.
161	Burner in a fault state	HBMU heat management unit data memory access fault	Reset the appliance. If the fault occurs repeatedly, replace the HBMU heat management unit. See chapter "Replacing the HBMU heat management unit".
163	Burner in a fault state	Checksum error, data memory access, HBMU heat management unit	Reset the appliance. If the fault occurs repeatedly, replace the HBMU heat management unit. See chapter "Replacing the HBMU heat management unit".
182	No DHW heating	Short circuit, outlet temperature sensor (if installed)	Check outlet temperature sensor (plug X7, cores 3 and 4). Measure sensor input on HBMU heat management unit. Set value: 3.3 V– with sensor disconnected
183	No DHW heating	Lead break, outlet temperature sensor (if installed)	Check outlet temperature sensor (plug X7, cores 3 and 4).
184	Burner in a fault state	Short circuit, flow temperature sensor/high limit safety cut-out	Check the flow temperature sensor/high limit safety cut-out. Check sensor lead. Replace faulty component if required. Reset the appliance.
185	Burner in a fault state	Lead break, flow temperature sensor/high limit safety cut-out	Check the flow temperature sensor/high limit safety cut-out. Replace faulty component if required. Reset the appliance.

Fault messages (cont.)

Displayed fault code	System characteristics	Cause	Measures
345	Burner locked out, automatic enabling after appliance cool-down. Independent restart	Temperature limiter has responded.	<ul style="list-style-type: none"> ▪ Ensure adequate heat transfer. ▪ Check heating system fill level. ▪ Check pre-charge pressure in diaphragm expansion vessel. Adjust to required system pressure. ▪ Check whether flow rate is sufficient (circulation pump). ▪ Check function of 3-way diverter valve. Vent the system. <p>If the fault occurs during DHW heating: Check DHW cylinder or plate heat exchanger for contamination and scaling.</p>
346	Burner in a fault state	Ionisation current calibration error	<ul style="list-style-type: none"> ▪ Check the gas supply pressure. ▪ Check gas solenoid valve strainer on the inlet side for contamination. ▪ Check ionisation electrode for contamination. ▪ Check flue system. Remove flue gas recirculation if required. ▪ Check the condensate drain (condensate blockage). <p>Reset the appliance.</p>
348	Burner in a fault state	Gas modulation valve	<p>If several heat generators are connected to a common flue system: Check whether "Multiple connections" is set in the commissioning assistant.</p> <p>Check the flue system for unrestricted flow.</p> <p>If fault remains, replace gas fan unit.</p>
349	Burner in a fault state	Air mass rate flow not detected correctly in fan unit.	<ul style="list-style-type: none"> ▪ Check for dust contamination in the supply air. ▪ Check burner gauze assembly for contamination. <p>Reset the appliance. If the fault occurs repeatedly, replace the gas fan unit.</p>
350, 351	Burner in a fault state	Ionisation current lies outside the permissible range	<p>Replace the HBMU heat management unit. See chapter "Replacing the HBMU heat management unit".</p>
352	Burner in a fault state	Combustion CO limit exceeded	<p>Check entire flue gas path for the following:</p> <ul style="list-style-type: none"> ▪ Leaks ▪ Flue gas back pressure caused by water pocket (if flue system fall is insufficient) ▪ Constrictions ▪ Blockages <p>Repair flue system if necessary. Reset the appliance.</p>



Fault messages (cont.)

Displayed fault code	System characteristics	Cause	Measures
353	Shutdown with restart if demand exists	Insufficient gas supply, burner output reduced	Check the gas supply. Optically check input-side screen in the gas solenoid valve for contamination. Reset the appliance.
354	Burner in a fault state	Gas modulation valve tolerance outside permissible range	Replace gas fan unit.
355	Burner in a fault state	Analogue signal reference check: Flame signal is already present at burner start.	Replace the HBMU heat management unit. See chapter "Replacing the HBMU heat management unit".
357	Burner in a fault state	Insufficient gas supply	<ul style="list-style-type: none"> ▪ Check that the main gas valve and the gas shut-off valve are open. ▪ Test static gas pressure and gas flow pressure. ▪ Check that on-site gas line and gas flow switch are correctly sized. <p>Note <i>If the building pressure regulator has a leak, you may notice rising pressure when the burner is idle. When the system is restarted, the gas flow switch may trip.</i></p> <ul style="list-style-type: none"> ▪ If the static pressure doesn't drop, check cable to the fan unit. Check that the coil resistance at the fuel valve is approx. 4 kΩ (plug 35). ▪ Check the ignition electrode for damaged insulation. <p>Reset the appliance.</p>
359	Burner in a fault state	No ignition spark	<ul style="list-style-type: none"> ▪ Check whether the ignition electrode insulation is damaged. ▪ Check for a voltage of 230 V~ at the ignition module during the ignition phase. If not, replace the HBMU heat management unit. ▪ If 230 V~ is present at the ignition module but there is still a fault, replace the ignition module. ▪ Check connection cables and leads from ignition module and ignition electrode. <p>Reset the appliance.</p>

Fault messages (cont.)

Displayed fault code	System characteristics	Cause	Measures
361	Burner in a fault state	Flame signal is not present or insufficient at burner start.	<p>Check ionisation electrode and connecting cable. Check plug-in connections for loose contacts.</p> <p>Note <i>Deposits on the electrodes indicate foreign bodies in the combustion air. Check the installation room and flue system for causes of the deposits. For example: Laundry detergents, cleaning agents, toilet-ries, deposits in the ventilation air supply (chimney)</i></p> <p>Reset the appliance.</p>
365	Burner in a fault state	Gas valve relay contact feedback implausible (relay contact is "welded up")	Replace the HBMU heat management unit.
366, 367	Burner in a fault state	Gas valve electricity supply does not turn off.	Replace the HBMU heat management unit. See chapter "Replacing the HBMU heat management unit".
369	Burner in a fault state	Flame is lost immediately after flame formation (during safety time)	<p>Check gas supply (gas pressure and gas flow switch). Check balanced flue system for flue gas recirculation.</p> <p>Check ionisation electrode for the following:</p> <ul style="list-style-type: none"> ▪ Clearance to burner gauze assembly. ▪ Contamination on electrode <p>Reset the appliance.</p>
370	Burner in a fault state	Gas valve or modulation valve will not close.	<p>Reset the appliance. If fault occurs repeatedly, replace fan unit.</p>

Fault messages (cont.)

Displayed fault code	System characteristics	Cause	Measures
372	Burner in a fault state	Repeated flame loss during calibration	<ul style="list-style-type: none"> ▪ Check ionisation electrode and connecting cable. ▪ Check plug-in connections for loose contacts. ▪ Check flue system. Remove flue gas recirculation if required. ▪ Check system for condensate backup. ▪ Visually inspect gas solenoid valve inlet and strainer on the inlet side for contamination. <p>Note <i>To prevent water damage, detach fan unit before removing the burner. Deposits on the electrodes indicate foreign bodies in the combustion air.</i></p> <p>Check the installation room and flue system for causes of the deposits. For example: Laundry detergents, cleaning agents, toilet-ries, deposits in the ventilation air supply (chimney). If burner gauze assembly and ionisation electrode have been replaced, also clean fan unit, gas/air channel and Venturi extension. Reset the appliance.</p>
373	Burner in a fault state	Heat transfer too low during calibration Temperature limiter has shut down.	<ul style="list-style-type: none"> ▪ Ensure adequate heat transfer. ▪ Check circulation pump for faults, scale or blockages. ▪ Check function of 3-way diverter valve. Vent the system. ▪ Check function of flow sensor. Reset the appliance.
377	Burner in a fault state	Post-processing ionisation current calibration: Stabilisation conditions for post-calibration not reached	Check gas type setting. If the fault occurs repeatedly, replace the HBMU heat management unit. See chapter "Replacing the HBMU heat management unit". Reset the appliance.
378	Burner in a fault state	Flame loss during stabilisation or operating phase	<ul style="list-style-type: none"> ▪ Check gas supply (gas pressure and gas flow switch). ▪ Check flue gas recirculation. ▪ Check for contamination of ionisation electrode and burner gauze assembly. Reset the appliance.
379	Burner in a fault state	Flame signal not present or insufficient	<ul style="list-style-type: none"> ▪ Check ionisation electrode connecting cable for damage and firm seating. ▪ Check ionisation electrode, replace if necessary. Reset the appliance.

Fault messages (cont.)

Displayed fault code	System characteristics	Cause	Measures
380	Burner in a fault state	Flame is lost immediately after flame formation (during safety time)	<p>Check gas supply (gas pressure and gas flow switch). Check balanced flue system for flue gas recirculation.</p> <p>Check ionisation electrode, burner gauze assembly:</p> <ul style="list-style-type: none"> ▪ Clearance to burner gauze assembly ▪ Contamination on electrode <p>Reset the appliance.</p>
381	Burner in a fault state	Flame loss during operating phase	<p>Check gas supply (gas pressure and gas flow switch). Check balanced flue system for flue gas recirculation.</p> <p>Check ionisation electrode, burner gauze assembly:</p> <ul style="list-style-type: none"> ▪ Clearance to burner gauze assembly. ▪ Contamination on electrode <p>Reset the appliance.</p>
382	Burner in a fault state	Fault counter has exceeded limit.	Reset the appliance. Work through fault analysis using fault history.
383, 384	Burner in a fault state	Possible contamination of gas line	<ul style="list-style-type: none"> ▪ Check gas line for contamination. ▪ Check the gas supply pressure. ▪ Replace gas fan if required. <p>Reset the appliance.</p>
385	Burner in a fault state	Short circuit, signal 1, ionisation current. HBMU heat management unit faulty.	Check IO electrode for earth fault. If the fault persists, replace the HBMU heat management unit. Reset the appliance.
386	Burner in a fault state	HBMU heat management unit faulty	Replace the HBMU heat management unit. See chapter "Replacing the HBMU heat management unit". Reset the appliance.
387	Burner in a fault state	Earth fault, ionisation current. HBMU heat management unit faulty.	Check ionisation electrode and connecting cable. If the fault persists, replace the HBMU heat management unit. See chapter "Replacing the HBMU heat management unit". Reset the appliance.
388	Burner in a fault state	HBMU heat management unit faulty	Replace the HBMU heat management unit. See chapter "Replacing the HBMU heat management unit". Reset the appliance.
395	Burner in a fault state	IO electrode earth fault, HBMU heat management unit faulty	Check ignition electrode for earth fault. If the fault persists, replace the HBMU heat management unit. Reset the appliance.

Fault messages (cont.)

Displayed fault code	System characteristics	Cause	Measures
396	Burner in a fault state	HBMU heat management unit faulty	Replace the HBMU heat management unit. See chapter "Replacing the HBMU heat management unit". Reset the appliance.
399	Burner in a fault state	IO electrode earth fault, HBMU heat management unit faulty	Check IO electrode for earth fault. If the fault persists, replace the HBMU heat management unit. See chapter "Replacing the HBMU heat management unit". Reset the appliance.
400	Burner in a fault state	HBMU heat management unit faulty	Replace the HBMU heat management unit. See chapter "Replacing the HBMU heat management unit". Reset the appliance.
401	Burner in a fault state	IO electrode earth fault, HBMU heat management unit faulty	Check IO electrode for earth fault. If the fault persists, replace the HBMU heat management unit. See chapter "Replacing the HBMU heat management unit". Reset the appliance.
402	Burner in a fault state	HBMU heat management unit faulty	Replace the HBMU heat management unit. See chapter "Replacing the HBMU heat management unit". Reset the appliance.
403	Burner in a fault state	Ionisation electrode earth fault, HBMU heat management unit faulty	Check IO electrode for earth fault. If the fault persists, replace the HBMU heat management unit. See chapter "Replacing the HBMU heat management unit". Reset the appliance.
404	Burner in a fault state	HBMU heat management unit faulty	Replace the HBMU heat management unit. See chapter "Replacing the HBMU heat management unit". Reset the appliance.
405	Burner in a fault state	Ionisation electrode earth fault, HBMU heat management unit faulty	Check IO electrode for earth fault. If the fault persists, replace the HBMU heat management unit. See chapter "Replacing the HBMU heat management unit". Reset the appliance.
406, 408, 410	Burner in a fault state	HBMU heat management unit faulty	Replace the HBMU heat management unit. See chapter "Replacing the HBMU heat management unit". Reset the appliance.
416	Burner locked out	Flue gas temperature sensor incorrectly positioned	Fit flue gas temperature sensor correctly. See "Repairs". Carry out mains reset after fault has been remedied.
417, 418	Burner in a fault state	HBMU heat management unit faulty	Replace the HBMU heat management unit. See chapter "Replacing the HBMU heat management unit". Reset the appliance.

Fault messages (cont.)

Displayed fault code	System characteristics	Cause	Measures
425	System in control mode, calculation out of operation. Calculation values can be viewed via software tool.	Time synchronisation failed	Set the time.
446	Burner in a fault state	Deviation, heat generator flow temperature sensor/high limit safety cut-out	Check the flow temperature sensor/high limit safety cut-out. Check plug-in connection and lead to sensor. Reset the appliance.
447, 448	Burner in a fault state	Deviation, ionisation voltage signal/Ionisation current	Replace the HBMU heat management unit. See chapter "Replacing the HBMU heat management unit". Reset the appliance.
449, 450, 451, 452	Burner in a fault state	Error in scheduled program run monitoring	Reset the appliance. If the fault occurs repeatedly, replace the HBMU heat management unit. See chapter "Replacing the HBMU heat management unit".
453	Burner in a fault state	Synchronisation error, sequence	Reset the appliance. If the fault occurs repeatedly, replace the HBMU heat management unit. See chapter "Replacing the HBMU heat management unit".
454	Burner in a fault state	Incorrect HBMU heat management unit parameter set	Flash correct HBMU heat management unit parameter set.
455, 456	Burner in a fault state	Error in program run monitoring	Reset the appliance. If the fault occurs repeatedly, replace the HBMU heat management unit. See chapter "Replacing the HBMU heat management unit".
457	Burner in a fault state	Fan sluggish or blocked.	Reset the appliance. Check fan for sluggishness. In the case of severe contamination or grinding noises, replace fan unit.
463	Burner in a fault state	Contaminated combustion air, flue gas recirculation	Check flue system for contamination and flue gas recirculation. Clean flue system if required. Reset the burner. Note <i>Deposits on the electrodes indicate foreign bodies in the combustion air. Check the installation room and flue system for causes of the deposits. For example: Laundry detergents, cleaning agents, toilet-ries, deposits in the ventilation air supply (chimney). If burner gauze assembly and ionisation electrode have been replaced, also clean fan unit, gas/air channel and Venturi extension. Reset the appliance.</i>



Fault messages (cont.)

Displayed fault code	System characteristics	Cause	Measures
464	Burner in a fault state	Ionisation current too low during calibration. Differential compared to previous value not plausible.	<ul style="list-style-type: none"> ▪ Check ionisation electrode and connecting cable. Check plug-in connections for loose contacts. ▪ Check whether there is a lot of dust in the ventilation air (e.g. from construction work). ▪ Check flue system. Remove flue gas recirculation if required. ▪ Check system for condensate backup. <p>Reset the appliance.</p> <p>Note <i>To prevent water damage, detach fan unit before removing the burner.</i></p> <p>If the fault is constantly present, replace the HBMU heat management unit: See chapter "Replacing the HBMU heat management unit."</p> <p>Note <i>Deposits on the electrodes indicate foreign bodies in the combustion air. Check the installation room and flue system for causes of the deposits. For example: Laundry detergents, cleaning agents, toilet-ries, deposits in the ventilation air supply (chimney). If burner gauze assembly and ionisation electrode have been replaced, also clean fan unit, gas/air channel and Venturi extension.</i></p>
467	Burner in a fault state	Gas supply insufficient during calibration. Contaminated or insufficiently sized gas line.	<ul style="list-style-type: none"> ▪ Test static gas pressure and gas flow pressure. ▪ Check that on-site gas line and gas flow switch are correctly sized. ▪ Visually inspect gas solenoid valve inlet and strainer on the inlet side for contamination. <p>Reset the appliance.</p> <p>Note <i>Contamination from a brazed gas line, for example, can block up the gas solenoid valve strainer on the inlet side.</i></p>

Fault messages (cont.)

Displayed fault code	System characteristics	Cause	Measures
468	Burner in a fault state	Ionisation current too high during calibration	<p>Check gap between ionisation electrode and burner gauze assembly.</p> <p>Check whether there is a lot of dust in the ventilation air (e.g. from construction work).</p> <p>Reset the appliance.</p> <p>Note <i>Deposits on the electrodes indicate foreign bodies in the ventilation air. Check the installation room and flue system for causes of the deposits. For example: Laundry detergents, cleaning agents, toilet-ries, deposits in the ventilation air supply (chimney).</i> <i>If burner gauze assembly and ionisation electrode have been replaced, also clean fan unit, gas/air channel and Venturi extension.</i></p>
471	No heat demand	System pressure sensor not available, lead break or short circuit	<ul style="list-style-type: none"> ▪ Check system pressure sensor (plug [163]). ▪ Check lead and plug-in connection. ▪ Measure, to see if supply voltage to sensor is 5 V–.
474	Burner in a fault state	Error in scheduled program run monitoring	<p>Reset the appliance.</p> <p>If the fault occurs repeatedly, replace the HBMU heat management unit. See chapter "Replacing the HBMU heat management unit".</p>
517	Control mode, remote control unit not functioning	Lead break, PlusBus cable, incorrect appliance address set, remote control faulty	<ul style="list-style-type: none"> ▪ Check setting in the commissioning assistant and correct as necessary. ▪ Check remote control cable. ▪ Check remote control subscriber number. Replace faulty remote control if applicable.
527, 528	Burner in a fault state	Incorrect HBMU heat management unit parameter set	<p>Overwrite (flash) the HBMU heat management unit with the correct parameter set.</p>



Fault messages (cont.)

Displayed fault code	System characteristics	Cause	Measures
540	Burner in a fault state	Condensate backup in the heat cell	<ul style="list-style-type: none"> ▪ Check system for condensate backup. ▪ Check the condensate drain and trap. ▪ Replace insulation blocks, electrodes and burner gauze assembly if required. <p>Note To prevent water damage, detach fan unit before removing the burner.</p> <p>Reset the appliance.</p>
544	Emergency function operating mode is activated for heating circuit 2: Mixer closes. Heating circuit pump is operational.	Lead break, flow temperature sensor, heating circuit 2 with mixer Incorrect setting during commissioning	<p>Check flow temperature sensor, mixer 2. Measure voltage at sensor input on electronics module. Set value: 3.3 V– with sensor disconnected. Check setting in the commissioning assistant and correct if required. Checking setting of ADIO rotary switch.</p>
545	Emergency function operating mode is activated for heating circuit 2: Mixer closes. Heating circuit pump is operational.	Short circuit, flow temperature sensor for heating circuit 2 with mixer	<p>Check flow temperature sensor, mixer 2. Measure voltage at sensor input on electronics module. Set value: 3.3 V– with sensor disconnected</p>
574	Room temperature sensor for heating circuit 1 not available	Normal operation without room influence	Check external room temperature sensor in heating circuit or room temperature sensor on remote control unit
738	Normal operation	OpenTherm remote control unit connected but not configured	Set C.7 in the commissioning assistant to a value of 14.

Repairs

Draining the boiler on the heating water side



Please note

Risk of scalding

Residual water will escape when the boiler or one of the following components is fitted or removed:

- Water-filled pipework
- Circulation pumps
- Plate heat exchanger
- Components fitted in the heating water or DHW circuit.

Water ingress can result in damage to other components.

Protect the following components against ingress of water:

- Control unit (especially in the service position)
- Electrical components
- Plug-in connections
- Electrical cables/leads

Only drain the boiler or heating system when the boiler water or cylinder temperature has dropped below 40 °C.

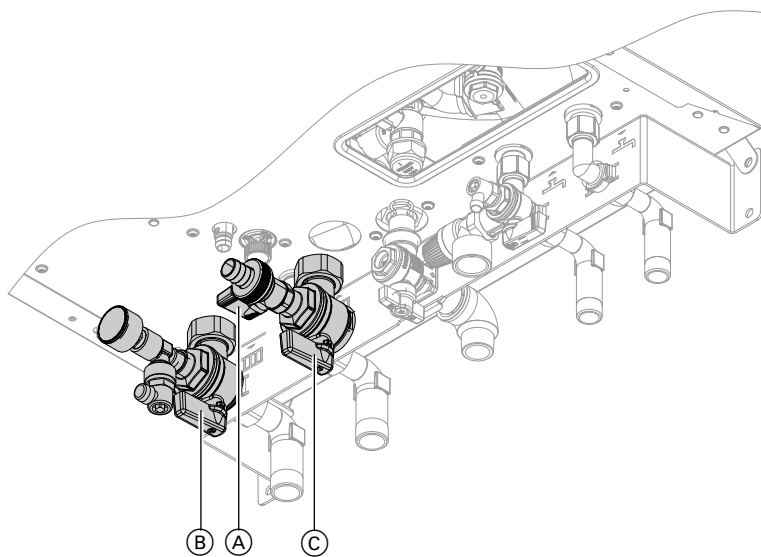

Fig. 40

1. Switch on the control unit. Call up the actuator test and put the diverter valve into its central position (see "Actuator and sensor test").
2. Wait until the valve has moved into its central position (approx. 5 s), then turn off the ON/OFF switch "ⓘ" on the control unit.
3. Route hose at drain valve (A) into a suitable container or drain outlet.
4. Close heating flow shut-off valve (B) and heating return shut-off valve (C).
5. Open drain valve (A). Drain the boiler as much as necessary.

Note

Residual water will remain in the boiler.

Draining the boiler on the DHW side

- !** **Please note**
Risk of scalding
Only drain the boiler or heating system when the boiler water or cylinder temperature has dropped below 40 °C.

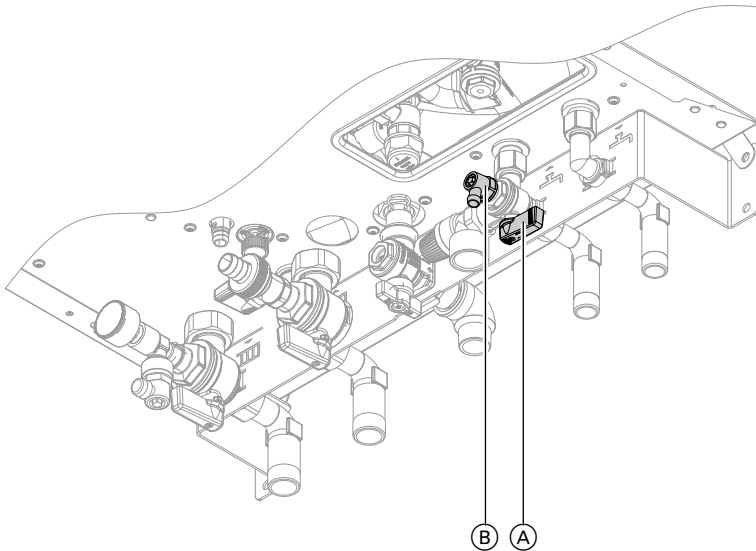

Fig. 41

1. Close cold water shut-off valve (A).
2. Connect hose to drain valve (B) and route it into a suitable container or drain outlet.
3. Open drain valve (B).

Note
*Ensure adequate ventilation in the DHW pipework.
Open hot water draw-off point.*

Repairs (cont.)

Removing the boiler from the pre-plumbing jig or mounting frame

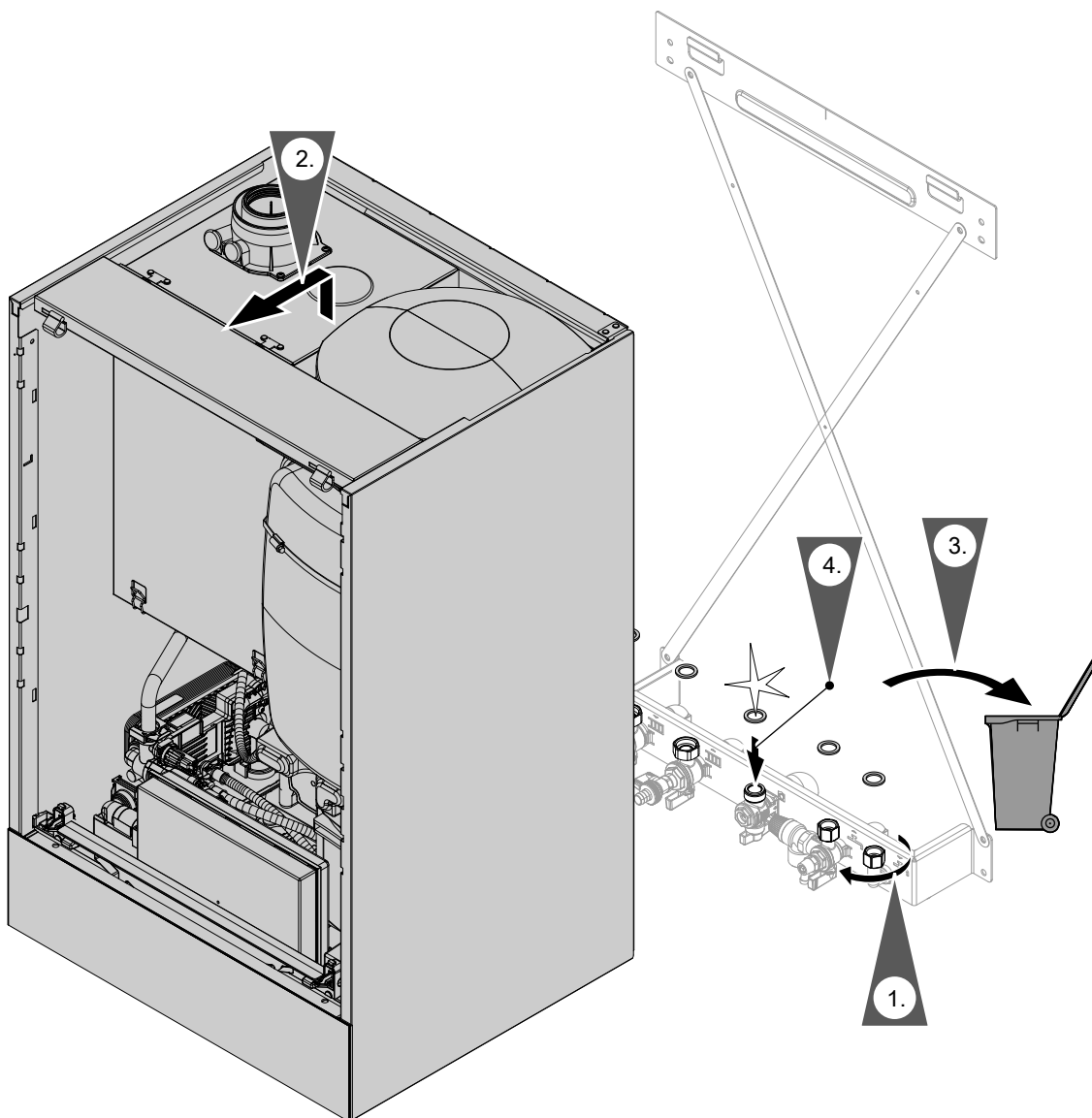

Fig. 42

Note

Use new gaskets when assembling.

Internal gasket diameter:

- Gas connection \varnothing 18.5 mm
- Connections on the heating water side \varnothing 17 mm
- Connections on the DHW side \varnothing 12 mm

Note

When carrying out any work on gas connection fittings, counterhold with a suitable tool. Never transfer any forces to the internal components.



Danger

Escaping gas leads to a risk of explosion. Check all connections on the gas side (also inside the appliance) for tightness.

Status/checking/diagnosing the internal circulation pump

The internal circulation pump is fitted with a status LED.

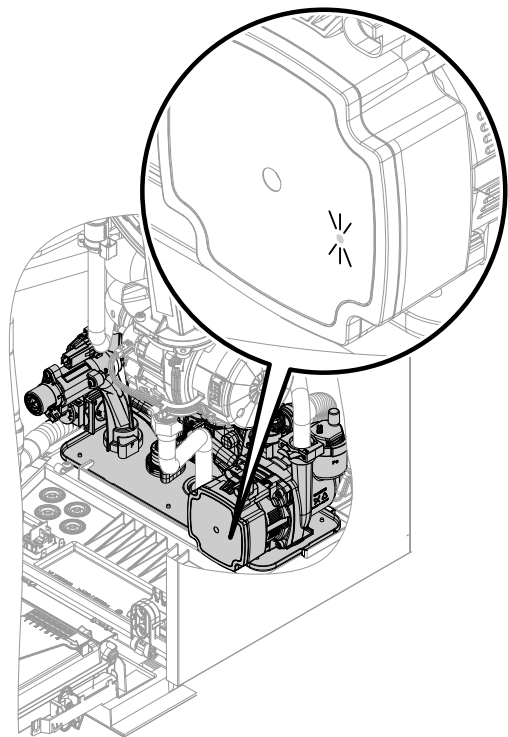

Fig. 43

- Constant green LED:
Pump is running without external control from the boiler controller
- Flashing green LED:
Pump is running with external control from the boiler controller
- Constant red LED:
Pump failure

Note

The pump is controlled by a PWM signal. A lead break in the data line will not generate a fault message. The pump is operating at 100 % of its maximum output.

Checking the temperature sensors

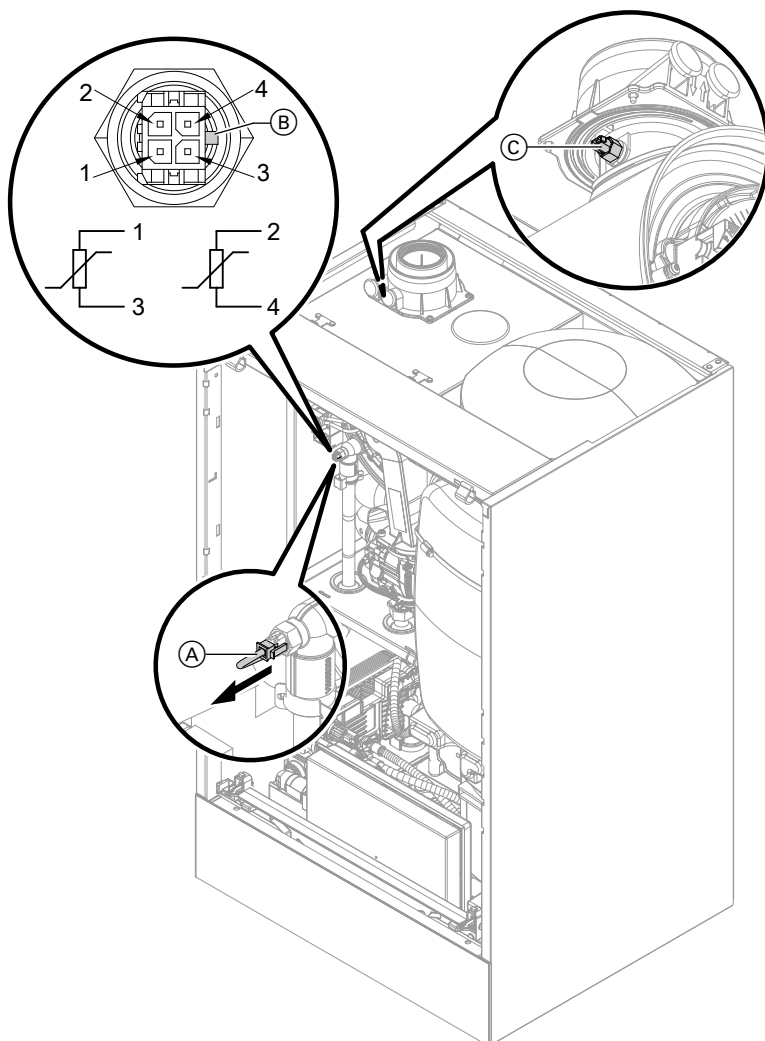

Fig. 44

Heat generator circuit flow temperature sensor (dual sensor)

1. Check the leads and plugs of flow temperature sensors (A).
2. Disconnect the leads from flow temperature sensors (A).



3. Check the sensor resistance. Note position of guide lug (B).
 - Sensor 1: Connections 1 and 3
 - Sensor 2: Connections 2 and 4

Compare the resistances with the value for the current temperature from the following diagram. In the event of severe deviation (> 10 %), replace the dual sensor.

⚠ Danger
The dual sensor is directly immersed in the heating water (risk of scalding). Drain the boiler on the heating water side before replacing the sensor.

⚠ Danger
Risk of electric shock from escaping heating water. Check the dual sensor for leaks.

Cylinder temperature sensor/outlet temperature sensor

1. Check lead and plug of cylinder temperature sensor  or outlet temperature sensor .
2. Disconnect wires of sensor plug.
3. Check the sensor resistance. Compare the resistance with the value for the current temperature from the following diagram.
In the event of severe deviation (> 10 %), replace the sensor.



Low loss header sensor

1. Check lead and plug of temperature sensor  on the ADIO electronics module (mixer extension kit).
2. Disconnect wires of sensor plug.
3. Check the sensor resistance. Compare the resistance with the value for the current temperature from the following diagram.
In the event of severe deviation (> 10 %), replace the sensor.

Outside temperature sensor

1. Check the lead and plug of the outside temperature sensor.
2. Disconnect wires 1 and 2 from the external plug.
3. Check the sensor resistance. Compare the resistance with the value for the current temperature from the following diagram.
If the results are very different from the curve (> 10 %), disconnect the wires from the sensor. Repeat the test directly on the sensor.
Check the on-site lead. 2-core lead, length up to 35 m with a cross-section of 1.5 mm²
Depending on the test result, replace the lead or the outside temperature sensor.

Flue gas temperature sensor

1. Check the lead and plug of flue gas temperature sensor .
2. Disconnect leads, flue gas temperature sensor .
3. Rotate sensor (anti-clockwise) by ¼ turn to remove it (bayonet fitting).
4. Check the sensor resistance. Compare the resistance with the value for the currently recorded temperature from the following diagram.
In the event of severe deviation (> 10 %), replace the sensor.
5. Rotate sensor (clockwise) by ¼ turn to install it.



Danger

Escaping flue gas can cause poisoning. When restarting, check for leaks on the flue gas side.

6. Reconnect leads, flue gas temperature sensor .
7. If the permissible flue gas temperature has been exceeded, the flue gas temperature sensor locks out the appliance. Reset the burner on the programming unit once the flue system has cooled down.

Repairs (cont.)

- Flue gas temperature sensor
- Flow temperature sensor
- Cylinder temperature sensor
- Outlet temperature sensor
- Temperature sensor, low loss header

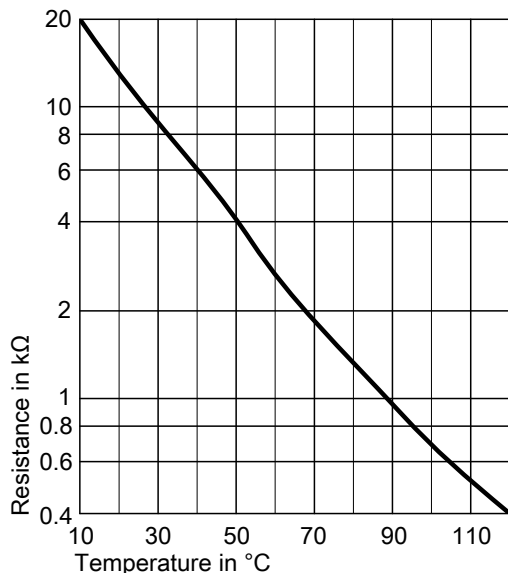

Sensor type: NTC 10 kΩ

- Outside temperature sensor

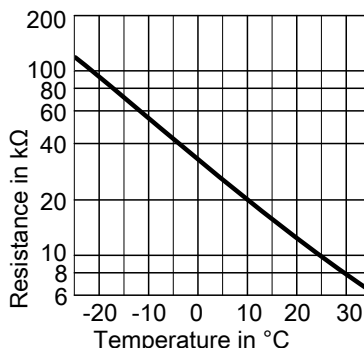

Sensor type: NTC 10 kΩ

Fault during commissioning (fault message 416)

During commissioning, the control unit checks for correct placement of the flue gas temperature sensor. If fault message 416 is displayed:

1. Check whether the flue gas temperature sensor is correctly installed (bayonet fitting). See previous diagram.
2. If required, correct the position of the flue gas temperature sensor.
3. Check the flue gas temperature sensor resistance. See previous chapter. Replace faulty flue gas temperature sensor if required.

4. Turn off the ON/OFF switch.
5. Turn the ON/OFF switch back on. Restart the commissioning assistant.
6. Check for leaks on the flue gas side.

Note

If fault message 416 continues to be displayed although the flue gas temperature sensor is correctly positioned: Initial commissioning may result in burner faults e.g. caused by air in the gas line. Eliminate the fault and reset the appliance.

Information on replacing the HBMU heat management unit

If replacing the HBMU heat management unit, the "Vitoguide app" must be used.



See spare part installation instructions and internet address: "www.vitoguide.info"

Replacing the power cable

When replacing the power cable, only use the power cable available as a spare part from Viessmann.

Replacing the HMI connecting cable

- !** **Please note**
 Incorrect routing of the cable can lead to heat damage and impairment of the EMC properties. For positioning and securing of the cable (fixing point of the cable tie) see connecting cable installation instructions.

Checking the plate heat exchanger

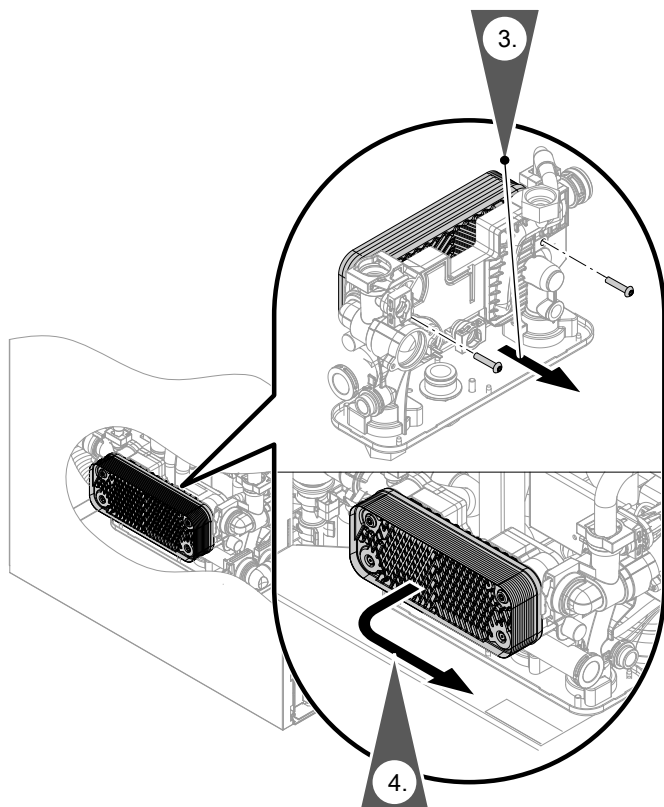

Fig. 45

1. Drain the boiler on the heating water and DHW sides.
2. Move the programming unit to the service position.
3. Undo the fixing screws.
4. Detach the plate heat exchanger and remove towards the front.
5. Check connections on the heating water and DHW sides for contamination and scaling. Replace plate heat exchanger if necessary.
6. Install in reverse order using new gaskets. Tighten screws as tightly as necessary and ensure that the components are undamaged and are functioning correctly throughout service life. Observe torque settings if a torque wrench is available.
Torque for fixing screws 3.2 Nm



Danger
 Risk of electric shock from escaping heating water or DHW.
 Check all water side connections for tightness.

Repairs (cont.)

Removing the hydraulic unit

If components of the hydraulic unit have to be replaced.

! **Danger**
 Risk of electric shock from escaping heating water or DHW.
 After installation, check all connections on the water side for leaks.

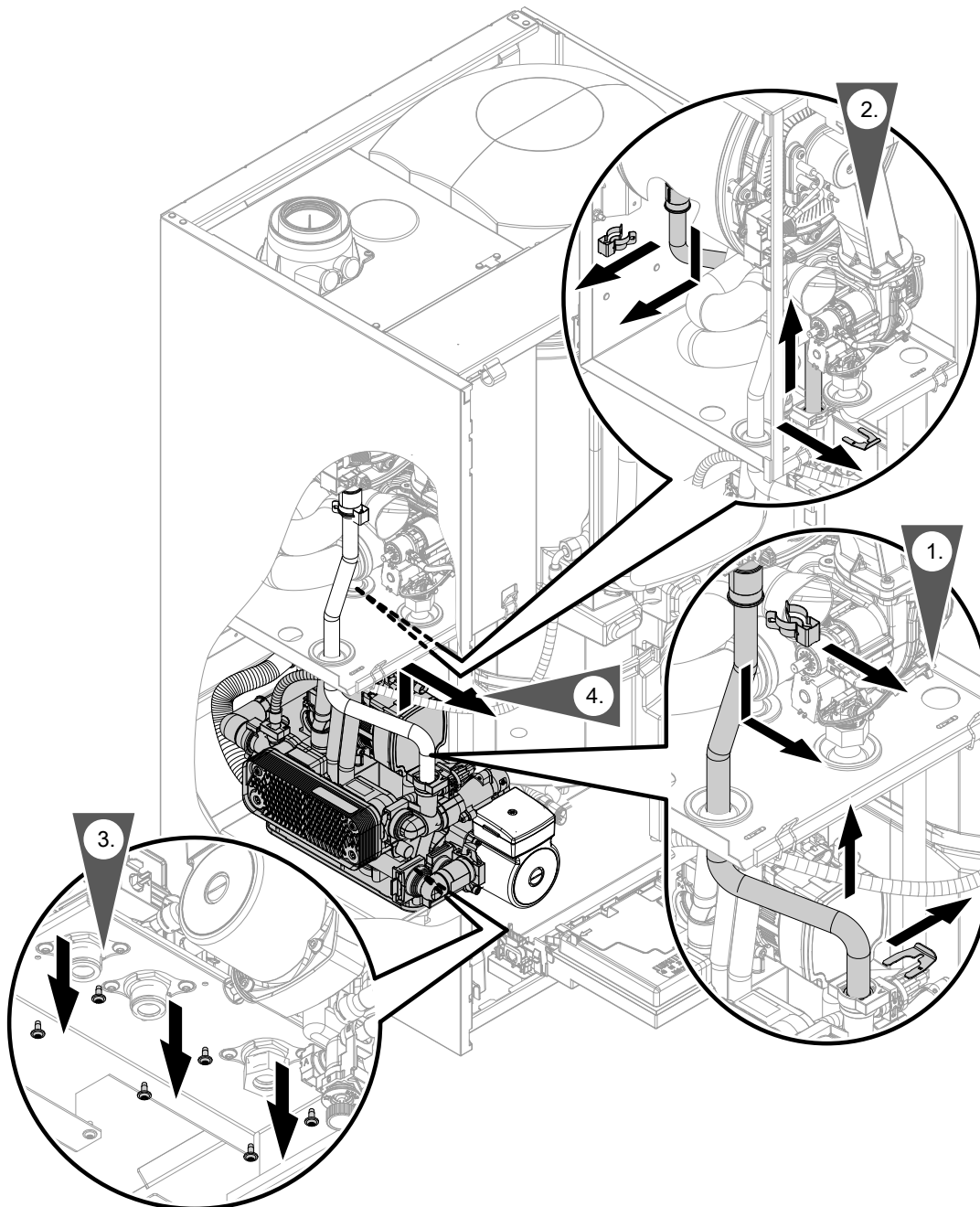

Fig. 46

Checking the fuse

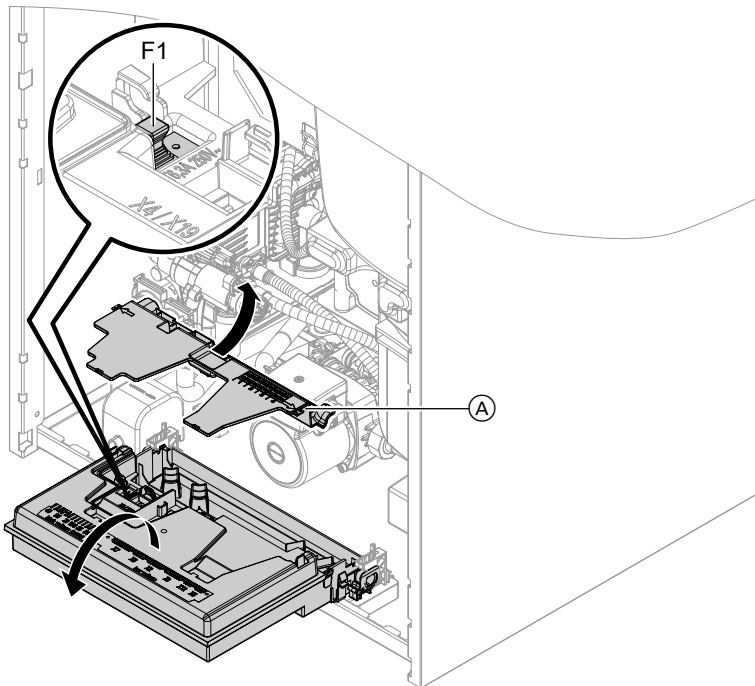

Fig. 47

1. Turn off the ON/OFF switch.
2. Depending on the layout: Move programming unit together with bracket to service position.
3. Pivot the HBMU heat management unit down.
4. Remove cover (A).
5. Check fuse F1 (see connection and wiring diagram).



Danger

Incorrect or improperly fitted fuses can lead to an increased risk of fire.

- Insert fuses without using any force. Position fuses correctly.
- Only use structurally identical types with the specified response characteristics.

Appliance functions

Heating mode

- **Weather-compensated operation:**

The rooms are heated in accordance with the room temperature and time program settings.

The control unit determines a set flow temperature for the heat generator, subject to the outside temperature, the room temperature and the slope/level of the heating curve.

- **Room temperature-dependent operation (constant operation with room thermostat):**

System with one heating circuit without mixer. The rooms are heated in accordance with the settings of the room temperature controller/room thermostat (accessories).

If the room temperature controller/room thermostat issues a demand, the standard set flow temperature is maintained. If there is no demand present, the reduced set flow temperature is maintained.

- **Constant operation without room thermostat:**

The rooms are heated according to the time program settings.

In the time phases at standard room temperature, the standard set flow temperature or the set comfort flow temperature is maintained. Outside the set time phases, the reduced set flow temperature is maintained.

- **OpenTherm:**

Rooms are heated in accordance with the settings of the room temperature controller/room thermostat (accessories). The OpenTherm controller specifies the flow temperature for the heat generator.

Venting program

During the venting program, the circulation pump will be alternately switched on and off for 30 s over a period of 20 min.

The 3-way diverter valve alternates between central heating and DHW heating for a certain period of time. The burner is switched off during the venting program.



Activate venting program: See "Commissioning, inspection and maintenance".

Filling program

In the delivered condition, the 3-way diverter valve is set to its central position, so the system can be filled completely. After the control unit has been switched on, the 3-way diverter valve no longer goes into its central position.

If the system is to be filled with the control unit switched on, the 3-way diverter valve is moved to its central position in the filling program and the pump is started.



Activate filling program: See "Commissioning, inspection and maintenance".

In this position, the control unit can be switched off and the system can be filled completely. When the function is enabled, the burner shuts down. The program automatically becomes inactive after 20 min.

Heating curve

The heating curves represent the relationship between the outside temperature and the flow temperature. Simplified: The lower the outside temperature, the higher the flow temperature must be in order to reach the room temperature set point.

Factory settings:

- Slope = 1.4
- Level = 0

Note

If heating circuits with mixer are present in the heating system: The flow temperature of the heat generator is one differential temperature higher than the flow temperature for the heating circuits with mixer. Differential temperature in delivered condition set to 8 K.

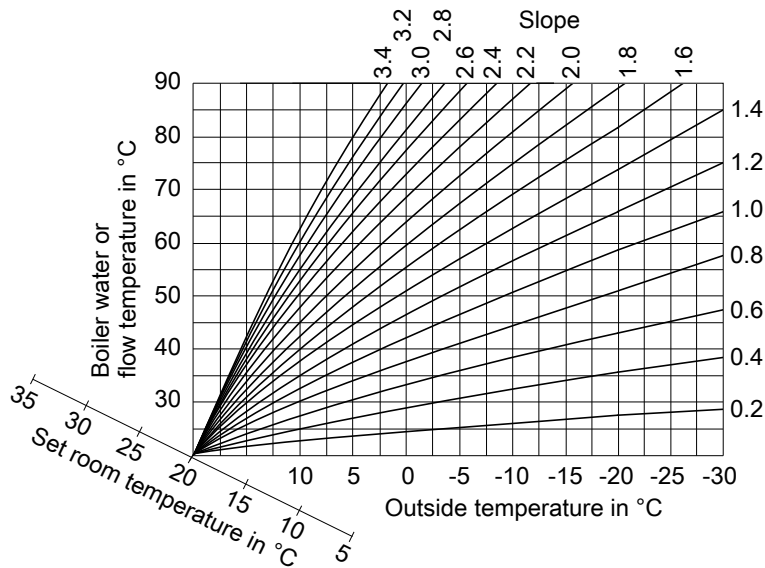

Fig. 48

Slope setting ranges:

- Underfloor heating systems: 0.2 to 0.8
- Low temperature heating systems: 0.8 to 1.6

Set room temperature

Standard room temperature or comfort room temperature

Individually adjustable for each heating circuit. The heating curve is offset along the set room temperature axis. The start and stop points of the heating circuit pumps depend on the Heating limit... outside temperature, heating circuit... setting.

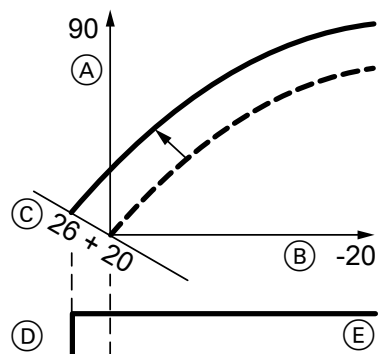

Fig. 49 Example 1: Changing the set room temperature from 20 to 26 °C

- (A) Flow temperature in °C
- (B) Outside temperature in °C
- (C) Set room temperature in °C
- (D) Heating circuit pump "OFF"
- (E) Heating circuit pump "ON"

Changing the set room temperature

Operating instructions

Reduced room temperature

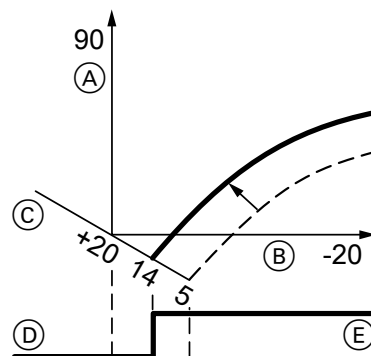

Fig. 50 Example 2: Changing the reduced set room temperature from 5 °C to 14 °C

- (A) Flow temperature in °C
- (B) Outside temperature in °C
- (C) Set room temperature in °C
- (D) Heating circuit pump "OFF"
- (E) Heating circuit pump "ON"

Changing the reduced set room temperature

Operating instructions

Changing the slope and level

Individually adjustable for each heating circuit.

Appliance functions (cont.)

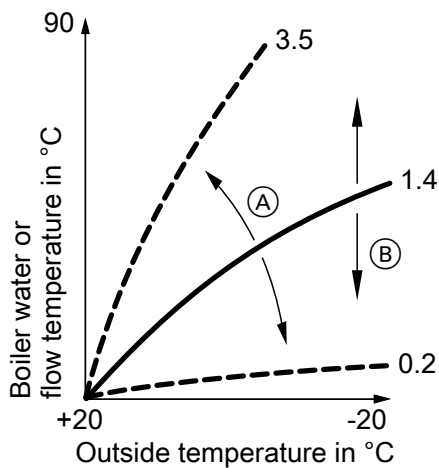

Fig. 51

- (A) Changing the slope
- (B) Changing the level (vertical parallel offset of the heating curve)

Screed drying

When enabling screed drying, observe the information provided by the screed manufacturer.

When the screed drying function is activated, the heating circuit pumps of **all** heating circuits are switched on and the flow temperature is maintained in accordance with the selected profile. After completion (30 days), the heating circuits with mixer are automatically controlled with the set parameters.

Screed drying is adjusted in the system configuration:

- 0 = OFF
- 2 = Temperature profile A
- 3 = Temperature profile B
- ...
- 7 = Temperature profile F

Note

During screed drying, DHW heating is not available.

Parameter "Screed drying":

Temperature profile A (EN 1264-4)

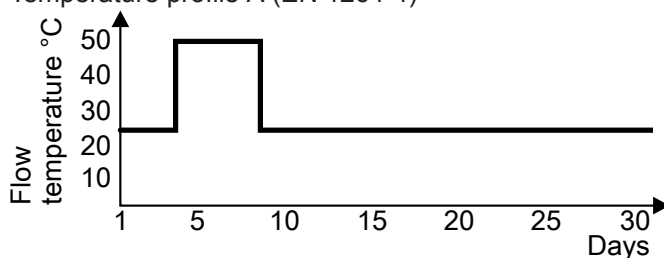

Fig. 52

Observe EN 1264. The report to be provided by the heating contractor must contain the following details regarding heat-up:

- Heat-up data with the relevant set flow temperatures
- Max. flow temperature achieved.
- Operating state and outside temperature at handover

Note

Temperature profile 6 ends after 21 days.

The function continues after a power failure or after the control unit has been switched off. When screed drying has completed or been manually switched off, the system is controlled in accordance with the selected parameters.

Function description

Appliance functions (cont.)

Temperature profile B (ZV parquet and flooring technology)

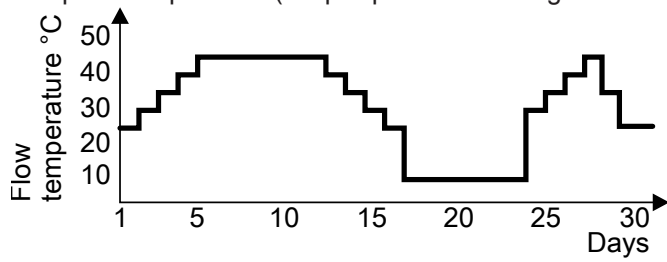

Fig. 53

Temperature profile C

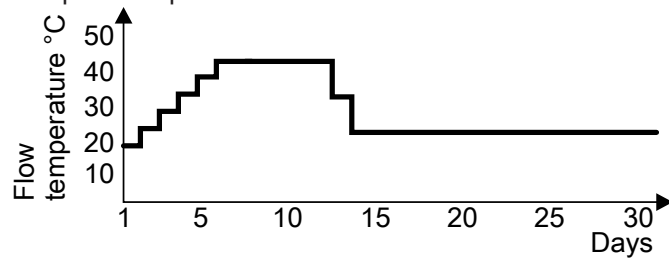

Fig. 54

Temperature profile D

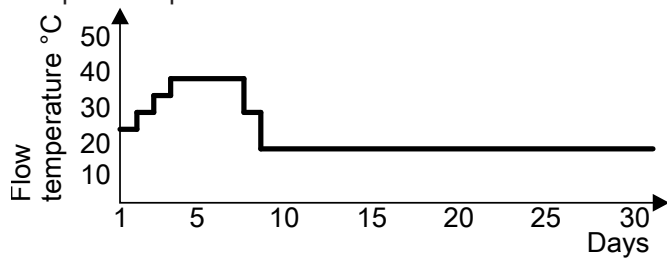

Fig. 55

Temperature profile E

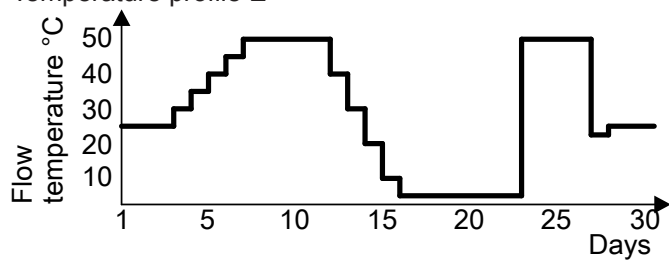

Fig. 56

Temperature profile F

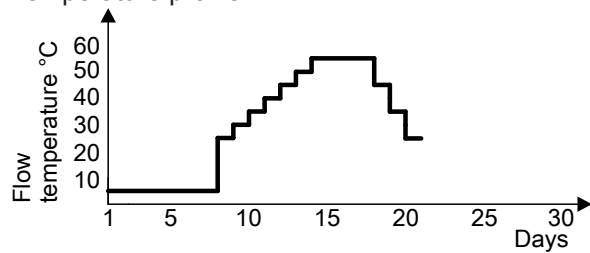

Fig. 57 Ends after 21 days.

DHW heating

Heating the DHW loading cylinder from cold

The heating circuit pump is switched ON and the 3-way diverter valve will be changed over, if the cylinder temperature sensor captures a temperature lower than the defaulted set value.

- The cylinder loading pump is switched ON if the boiler water temperature \geq set cylinder temperature.
- The burner is switched ON if the boiler water temperature \leq set cylinder temperature, and the cylinder loading pump is switched ON when the required boiler water temperature is reached.

The loading cylinder is heated up to the set cylinder temperature. Heating stops when the specified temperature has been reached at the cylinder temperature sensor.

Reheating when DHW is drawn off

When DHW is drawn off, cold water enters the lower section of the loading cylinder.

The heating circuit pump is switched ON and the 3-way diverter valve is changed over, if the cylinder temperature sensor captures a temperature lower than the defaulted set value.

- The cylinder loading pump is switched ON if the boiler water temperature \geq set cylinder temperature.
- The burner is switched ON if the boiler water temperature \leq set cylinder temperature, and the cylinder loading pump is switched ON when the required boiler water temperature is reached.

DHW is regulated to the set temperature via the outlet temperature sensor.

After the draw-off process has ended, the loading cylinder continues to be heated up until the set DHW temperature is reached at the cylinder temperature sensor.

External heating circuit hook-up (if installed)

Note

Only in conjunction with weather-compensated operation.

- Function:
 - If the external demand is active (plug 96 or digital input on EM-EA1 (DIO) electronics module closed), the heating circuit is supplied with heat.
 - If the external demand is inactive (contact open), heat supply to the heating circuit ends (regardless of the current set room temperature or the switching time).



Please note

There is no frost protection for the connected heating circuits.

- Connection:
 - If only one heating circuit is hooked up, use connection at plug 96: See page 25.
 - If multiple heating circuits are hooked up, connect all contacts to EM-EA1 extension (DIO electronics module) with the subscriber number. 1 (rotary switch = 1).



See EM-EA1 extension installation instructions

Note

Perform the hook-up with subscriber number "1".

HBMU heat management unit

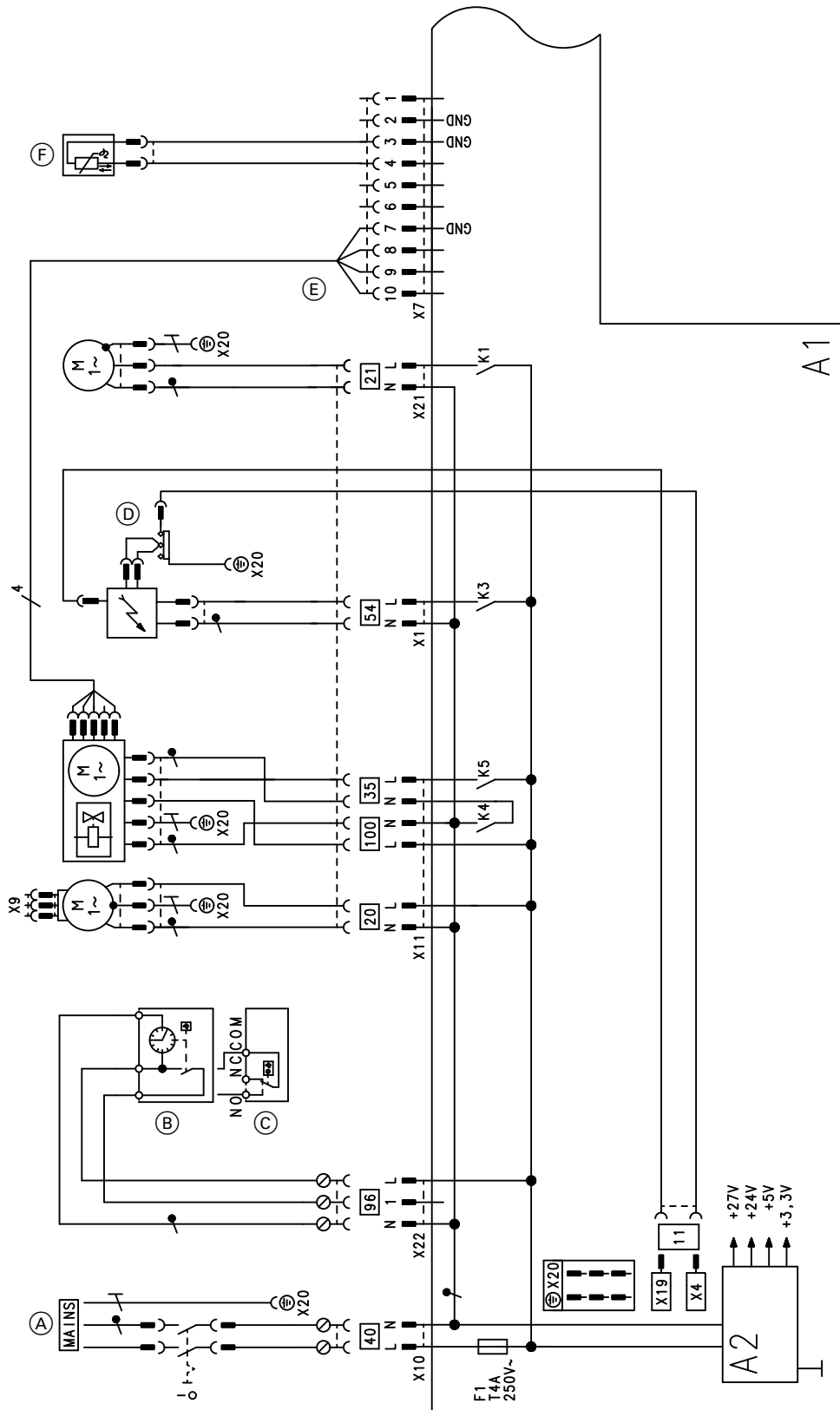

Fig. 58

- A1 HBMU heat management unit
- X... Electrical interfaces
- A2 Power supply unit
- (A) Power supply 40
- (B) Vitotrol 100, type UTA
- (C) Vitotrol 100, type UTDB
- (D) Ignition unit/ionisation 54

- (F) Outlet temperature sensor
- 35 Gas solenoid valve
- 100 Fan motor
- (E) Fan motor control
- 96 230 V connection accessories
- 20 Heating circuit pump
- 21 Cylinder loading pump

(cont.)

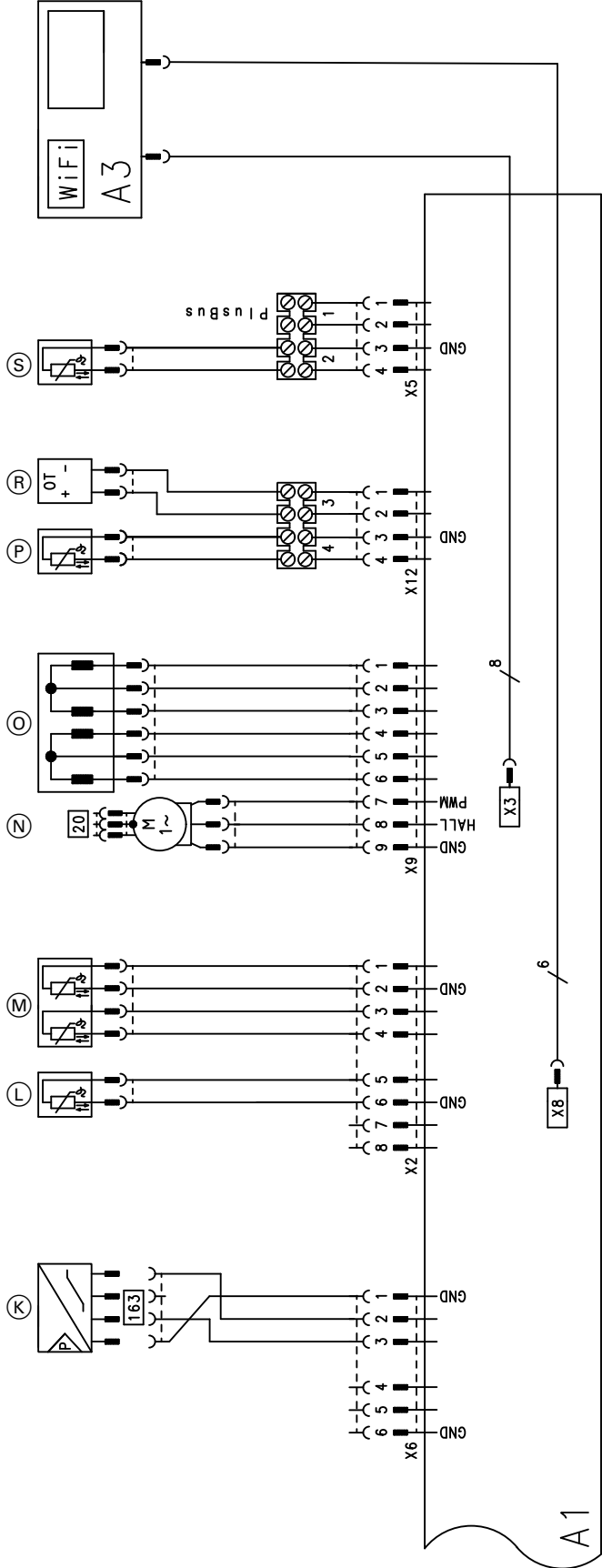

Fig. 59

- A1 HBMU heat management unit
- A3 Programming unit with communication module (TCU 100)
- X... Electrical interfaces

- (K) Water pressure sensor
- (L) Flue gas temperature sensor
- (M) Boiler water temperature sensor
- (N) Circulation pump (PWM)

6167665

Connection and wiring diagram

(cont.)

- Ⓞ Diverter valve stepper motor
- Ⓟ Outside temperature sensor

- Ⓡ Remote control (OpenTherm device)
- Ⓢ Cylinder temperature sensor

Commissioning/service reports

Settings and test values		Set value	Commissioning	Maintenance/service	Maintenance/service
Date					
Signature					
Static pressure	mbar kPa	≤ 57.5 ≤ 5.75			
Supply pressure (flow pressure)					
<input type="checkbox"/> For natural gas	mbar kPa	See table "Supply pressure" (Commissioning ...)			
<input type="checkbox"/> For LPG	mbar kPa				
<input type="checkbox"/> Enter gas type					
Carbon dioxide content CO₂					
For natural gas					
▪ At lower heating output	% by vol.	See "Checking the combustion quality" (Commissioning ...)			
▪ At upper heating output	% by vol.				
For LPG					
▪ At lower heating output	% by vol.				
▪ At upper heating output	% by vol.				
Oxygen content O₂					
▪ At lower heating output	% by vol.				
▪ At upper heating output	% by vol.				
Carbon monoxide content CO					
▪ At lower heating output	ppm	< 1000			
▪ At upper heating output	ppm	< 1000			

Specification

Specification

Note

The supply values are only for reference (e.g. in the gas contract application) or for a supplementary, rough estimate to check the volumetric settings. Due to factory settings, the gas pressure must not be altered from these values. Reference: 15 °C, 1013 mbar (101.3 kPa).

Specification

Gas boiler, type B and C, category II_{2N3P}

Type	B1LF		
Rated heating output range (details to EN 15502)			
$T_F/T_R = 50/30 \text{ °C (P(50/30))}$			
Natural gas	kW	3.2 (5.7) - 25.0	3.2 (5.7) - 32.0
LPG	kW	3.2 - 25.0	3.2 - 32.0
$T_F/T_R = 80/60 \text{ °C (Pn(80/60))}$			
Natural gas	kW	2.9 (5.2) - 23	2.9 (5.2) - 29.3
LPG	kW	2.9 - 23	2.9 - 29.3
Rated heating output for DHW heating			
Natural gas	kW	2.9 (5.1) - 31.1	2.9 (5.1) - 34.6
LPG	kW	2.9 - 31.1	2.9 - 34.6
Rated heat input (Qn)			
Natural gas	kW	3.0 (5.3) - 23.4	3.0 (5.3) - 29.9
LPG	kW	3.0 (5.3) - 23.4	3.0 (5.3) - 29.9
Rated heat input for DHW heating (Qnw)			
		31.7	34.9
Natural gas	kW	3.0 (5.3) - 31.7	3.0 (5.3) - 34.9
LPG	kW	3.0 - 31.7	3.0 - 34.9
Product ID		CE-0085DL0217	
IP rating		IP X1 to EN 60529	
NO_x	Class	6	6
Gas supply pressure			
Natural gas	mbar	20	20
	kPa	2	2
LPG	mbar	50	50
	kPa	5	5
Max. permiss. gas supply pressure*¹			
Natural gas	mbar	13 - 25.0	13 - 25.0
	kPa	1.3 - 2.5	1.3 - 2.5
LPG	mbar	25 - 57.5	25 - 57.5
	kPa	2.5 - 5.75	2.5 - 5.75
Rated voltage	V	230	
Rated frequency	Hz	50	
Appliance fuse protection	A	4.0	
Backup fuse (power supply)	A	16	
Communication module (integral)			
WiFi frequency band	MHz	2400 - 2483.5	

*¹ If the gas supply pressure is higher than the maximum permissible value, install a separate gas pressure governor upstream of the system.

Specification (cont.)

Gas boiler, type B and C, category II_{2N3P}

Type		B1LF	
Rated heating output range (details to EN 15502)			
$T_F/T_R = 50/30 \text{ °C (P(50/30))}$			
Natural gas	kW	3.2 (5.7) - 25.0	3.2 (5.7) - 32.0
LPG	kW	3.2 - 25.0	3.2 - 32.0
$T_F/T_R = 80/60 \text{ °C (Pn(80/60))}$			
Natural gas	kW	2.9 (5.2) - 23	2.9 (5.2) - 29.3
LPG	kW	2.9 - 23	2.9 - 29.3
Max. transmitting power	dBm	20	
Low power radio frequency band	MHz	2400 - 2483.5	
Max. transmitting power	dBm	10	
Supply voltage	V \equiv	24	
Power consumption	W	4	
Sound power level (to EN ISO 15036-1)			
At partial load	dB(A)	35	35
At rated heating output (DHW heating)	dB(A)	51.1	52.9
Power consumption (delivered condition)	W	71	110
Permissible ambient temperature			
▪ During operation	°C	+5 to +35	
▪ During storage and transport	°C	-5 to +60	
Electronic temperature limiter setting (TN)	°C	91	
Electronic temperature cut-out setting	°C	110	
Weight			
– Excl. heating water and DHW	kg	67.8	67.8
– Incl. heating water and DHW	kg	120.0	120.0
Water capacity (excl. diaphragm expansion vessel)	l	3.0	3.0
Max. flow temperature	°C	82	82
Max. flow rate (Limit for the use of hydraulic separation)	l/h	See residual head graphs	
Nominal circulating water volume At $T_F/T_R = 80/60 \text{ °C}$	l/h	988	1259
Expansion vessel			
Capacity	l	10	10
Pre-charge pressure	bar	0.75	0.75
	kPa	75	75
Permiss. operating pressure	bar	3	3
	MPa	0.3	0.3
Connections (with connection accessories)			
Boiler flow and return	R	$\frac{3}{4}$	$\frac{3}{4}$
Cold water and DHW	G	$\frac{1}{2}$	$\frac{1}{2}$
Dimensions			
Length	mm	500	500
Width	mm	600	600
Height	mm	950	950
Gas connection (with connection accessories)	R	$\frac{3}{4}$	$\frac{3}{4}$



Specification

Specification (cont.)

Gas boiler, type B and C, category II_{2N3P}

Type	B1LF		
Rated heating output range (details to EN 15502)			
$T_F/T_R = 50/30 \text{ °C (P(50/30))}$			
Natural gas	kW	3.2 (5.7) - 25.0	3.2 (5.7) - 32.0
LPG	kW	3.2 - 25.0	3.2 - 32.0
$T_F/T_R = 80/60 \text{ °C (Pn(80/60))}$			
Natural gas	kW	2.9 (5.2) - 23	2.9 (5.2) - 29.3
LPG	kW	2.9 - 23	2.9 - 29.3
DHW loading cylinder			
Capacity	l	46	46
Permiss. operating pressure (DHW side)	bar	10	10
	MPa	1	1
Continuous DHW output	kW	30.3	33.9
For DHW heating from 10 to 45 °C	l/h	726.6	813.6
Performance factor N_L^{*2}		1.5	1.7
Initial DHW output	l/10 min	170.3	180.8
For DHW heating from 10 to 45 °C			
Supply values			
Relative to the max. load and 1013 mbar/15 °C			
Natural gas E	m ³ /h	3.35	3.69
Natural gas LL	m ³ /h	3.90	4.29
LPG	kg/h	2.46	2.71
Flue gas parameters			
Temperature (at a return temperature of 30 °C)			
– At rated heating output	°C	46	59
– At partial load	°C	38	38
Temperature (at a return temperature of 60 °C)			
	°C	74	77
Mass flow rate (for DHW heating)			
Natural gas			
– At rated heating output	kg/h	57.3	62.1
– At partial load	kg/h	5.6 (9.8)	5.6 (9.8)
LPG			
– At rated heating output	kg/h	57.1	61.1
– At partial load	kg/h	3.9	3.9
Available draught			
	Pa	250	250
	mbar	CH: 200	CH: 200
		2.5	2.5
		CH: 2	CH: 2

*² At 70 °C average boiler water temperature and cylinder storage temperature $T_{cyl} = 60 \text{ °C}$.

DHW performance factor N_L depends on cylinder storage temperature T_{cyl} .

Standard values: $T_{cyl} = 60 \text{ °C} \rightarrow 1.0 \times N_L$ $T_{cyl} = 55 \text{ °C} \rightarrow 0.75 \times N_L$ $T_{cyl} = 50 \text{ °C} \rightarrow 0.55 \times N_L$ $T_{cyl} = 45 \text{ °C} \rightarrow 0.3 \times N_L$.

Specification (cont.)

Gas boiler, type B and C, category II_{2N3P}

Type	B1LF		
Rated heating output range (details to EN 15502) $T_F/T_R = 50/30 \text{ °C (P(50/30))}$			
Natural gas	kW	3.2 (5.7) - 25.0	3.2 (5.7) - 32.0
LPG	kW	3.2 - 25.0	3.2 - 32.0
$T_F/T_R = 80/60 \text{ °C (Pn(80/60))}$			
Natural gas	kW	2.9 (5.2) - 23	2.9 (5.2) - 29.3
LPG	kW	2.9 - 23	2.9 - 29.3
Max. amount of condensate To DWA-A 251	l/h	4.1	4.9
Condensate connection (hose nozzle)	Ø mm	20 - 24	20 - 24
Flue gas connection	Ø mm	60	60
Ventilation air connection	Ø mm	100	100
Standard seasonal efficiency [to DIN] at $T_F/T_R = 40/30 \text{ °C}$	%	Up to 98 (H _s) [gross cv]	
Energy efficiency class			
- Heating		A	A
- DHW heating, draw-off profile XL		A	A

Note

The supply values are only for reference (e.g. in the gas contract application) or for a supplementary, rough estimate to check the volumetric settings. Due to factory settings, the gas pressure must not be altered from these values. Reference: 15 °C, 1013 mbar (101.3 kPa).

Flue system types

Available in the following countries	Flue system types
AE, AM, AT, AZ, BA, BG, BY, CH, CY, CZ, DK, EE, ES, FI, FR, GB, GR, HR, HU, IE, IS, IT, KG, KZ, LT, LV, MD, ME, MT, NL, NO, PL, PT, RO, RS, RU, SE, SK, TR, UA, UZ	B ₂₃ , B _{23P} , B ₃₃ , C ₁₃ , C ₃₃ , C ₅₃ , C ₆₃ , C ₈₃ , C _{83P} , C ₉₃ (C ₄₃ , C _{43P} , C ₍₁₀₎₃ , C ₍₁₁₎₃ , C ₍₁₃₎₃ , C ₍₁₄₎₃ ^{*3})
AU, BE, NZ	B ₂₃ , B _{23P} , B ₃₃ , C ₁₃ , C ₃₃ , C ₅₃ , C ₈₃ , C _{83P} , C ₉₃ (C ₄₃ , C _{43P} , C ₍₁₀₎₃ , C ₍₁₁₎₃ , C ₍₁₃₎₃ , C ₍₁₄₎₃ ^{*3})
DE, LU, SI	B ₂₃ , B _{23P} , B ₃₃ , C _{13X} , C _{33X} , C _{53X} , C _{63X} , C _{83X} , C _{93X} (C ₄₃ , C _{43P} , C ₍₁₀₎₃ , C ₍₁₁₎₃ , C ₍₁₃₎₃ , C ₍₁₄₎₃ ^{*3})
CN	C13

Gas categories

Available in the following countries	Gas categories
AE, AM, AT, DK, EE, KG, LV, LU, LT, RO, RU, SE, AZ, BA, BG, BY, CH, CZ, ES, FI, GB, GR, HR, IE, IS, KZ, IT, MD, ME, NO, PT, RS, SI, SK, TR, UZ, HU, MT, UA	II _{2N3P} /II _{2H3P}
AU, BE, NZ	I _{2N}
DE, FR	II _{2N3P}
CY	I _{3P}

*3 Only for specifically marked appliances.

Specification

(cont.)

Available in the following countries	Gas categories
NL	II _{2EK3P}
PL	II _{2N3P} /II _{2ELW3P}
CN	12T

The gas condensing appliance is suitable for operation with a hydrogen admixture of up to 20 % by volume.

Electronic combustion control unit

The electronic combustion controller utilises the physical correlation between the level of the ionisation current and the air ratio λ . The maximum ionisation current is achieved at an air ratio of 1 for all gas qualities. The ionisation signal is evaluated by the combustion controller. The air ratio is regulated to a value that is between $\lambda = 1.2$ and 1.5. This range provides for an optimum combustion quality. Thereafter, the electronic gas train regulates the required gas volume subject to the prevailing gas quality.

To check the combustion quality, the CO₂ content or the O₂ content of the flue gas is measured. The prevailing air ratio is determined using the actual values.

To achieve optimum combustion control, the system regularly carries out an automatic self-calibration; also after power failures (shutdown). For this, the combustion is briefly regulated to maximum ionisation current (corresponding to air ratio $\lambda = 1$). Self-calibration takes place shortly after the burner starts. The process lasts approx. 20 s during which higher than normal CO emissions may occur briefly.

Final decommissioning and disposal

Viessmann products can be recycled. Components and substances from the system are not part of ordinary domestic waste.

For decommissioning, isolate the system from the power supply and allow components to cool down where appropriate.
All components must be disposed of correctly.

Certificates

Declaration of conformity

We, Viessmann Climate Solutions SE, D-35108 Allendorf, declare as sole responsible body that the named product complies with the European directives and supplementary national requirements in terms of its design and operational characteristics. Viessmann Climate Solutions SE, D-35108 Allendorf, hereby declares that the radio equipment type of the named product is in compliance with Directive 2014/53/EU.

Using the serial number, the full Declaration of Conformity can be found on the following website:
www.viessmann.co.uk/eu-conformity

Manufacturer's certificate according to the 1st BImSchV [Germany]

We, Viessmann Climate Solutions SE, D-35108 Allendorf, confirm that the product **Vitodens 111-W** complies with the NO_x limits specified by the 1st BImSchV, paragraph 6 [Germany].

Allendorf, 1 September 2020

Viessmann Werke GmbH & Co. KG



Authorised signatory Reiner Jansen
Head of Strategic Quality Management

Keyword index

- A**
Angle of penetration..... 29
- B**
Back draught safety device..... 49
Boiler
– DHW side, draining..... 84
– Heating water side, draining..... 83
Boiler water temperature sensor..... 87
Burner gasket..... 48
Burner gauze assembly..... 48
Burner installation..... 52
Burner removal..... 46
- C**
Cold water connection..... 10
Combustion chamber cleaning..... 50
Combustion controller..... 106
Combustion quality, checking..... 55
Commissioning..... 36
Commissioning assistant..... 32
Condensate drain..... 51
Connection
– Condensate..... 18
– DHW..... 11, 18
– Heating water..... 18
Connections..... 10
Connection schemes..... 98
Control unit
– Wiring diagram..... 98
Control unit functions..... 93
Converting the gas type..... 39
Cylinder temperature sensor..... 87
- D**
DHCP..... 28
DHW connection..... 10
DHW expansion vessel
– Checking..... 54
DHW heating
– Functions..... 97
DHW hygiene..... 57
DHW temperature, raised..... 57
Diaphragm expansion vessel..... 37
Dynamic IP addressing..... 28
- E**
Electrical connections..... 22
Electronic combustion controller..... 106
Expansion vessel..... 53
- F**
Fault codes..... 67
Fault message, calling up..... 66
Fault messages
– Display..... 66
Faults
– Commissioning..... 42
– Display..... 66
Filling function..... 37, 93
Flow pressure..... 42
Flow temperature sensor..... 87
Flue gas temperature sensor..... 88
Front panel removal..... 17
Function descriptions..... 93
Function sequence..... 42
Fuse..... 92
- G**
Gas connection..... 10
Gas solenoid valve..... 41
Gas supply pressure..... 42
Gas type..... 39
Gas type conversion..... 39
- H**
Heating curve..... 57, 93
Heating curve level..... 94
Heating curve slope..... 94
Heating flow..... 10
Heating output, setting..... 43
Heating return..... 10
Heating surface cleaning..... 50
- I**
Ignition..... 49
Ignition electrodes..... 49
Installation preparation..... 10
Intended use..... 9
Internet, connecting..... 36
Ionisation electrode..... 49
IP addressing..... 28
- L**
Language selection..... 32
Leak test, balanced flue system..... 46
Loading cylinder, filling..... 38
- M**
Manufacturer's certificate 108
Message history..... 66
Multiple connection to shared flue system..... 46
- O**
Operating conditions, checking..... 65
Operating data, calling up..... 65
Operating data, checking..... 65
Operational reliability..... 28
Output adjustment
– Multiple connection..... 46
Outside temperature sensor..... 25, 87

P	
Parameter	
– Max. flow temperature, heating circuit.....	60, 61
– Max. speed, heating circuit pump.....	59
– Maximum heating output.....	60
– Minimum heating output.....	59
– Primary circuit pump operating mode.....	58
– Room temperature hook-up, heating circuit.....	60
– Scald protection activation.....	59
– Screed drying.....	59
– Set flow temperature for external demand.....	58
Parameters.....	58, 60
– Adjusting.....	58
– Calling up.....	58
– Energy saving functions, heating circuit.....	61, 62
Parameters for commissioning.....	56
Plate heat exchanger.....	90
Port 123.....	28
Port 443.....	28
Port 80.....	28
Port 8883.....	28
Product information.....	9
R	
Range of WiFi connections.....	28
Reduced set room temperature.....	94
Repairs.....	83
Report.....	101
Requirements.....	28
Room temperature, set	
– Setting.....	94
S	
Safety valve.....	10
Screed drying.....	95
Screed drying function.....	45, 95
Security parameters.....	28
Service menu	
– Calling up.....	64
– Exiting.....	64
Specification.....	102
Static pressure.....	41
Subscriber number	
– Extensions.....	62
– Setting.....	62
Subscriber number of connected component.....	66
Supply pressure.....	41, 42
Switch S1.....	62
Symbols.....	8
System configuration.....	32, 58
System filling.....	38
System pressure.....	38
System requirements.....	28
System schemes.....	56
T	
Trap.....	19, 51
V	
Venting function.....	38
Venting program.....	93
W	
Wall mounting bracket, fitting.....	15
WiFi connection.....	36
WiFi connection range.....	28
WiFi network.....	36
WiFi router.....	28
Wiring diagram.....	98



Viessmann Climate Solutions SE
35108 Allendorf
Telephone: +49 6452 70-0
Fax: +49 6452 70-2780
www.viessmann.com



Viessmann Limited
Hortonwood 30, Telford
Shropshire, TF1 7YP, GB
Telephone: +44 1952 675000
Fax: +44 1952 675040
E-mail: info-uk@viessmann.com

6167585 Subject to technical modifications.